



United States of America
 Department of Homeland Security
 United States Coast Guard

Certification Date: 10 Mar 2022

Expiration Date: 10 Mar 2027

Certificate of Inspection

For ships on international voyages this certificate fulfills the requirements of SOLAS 74 as amended, regulation V/14, for a SAFE MANNING DOCUMENT.

Vessel Name	Official Number	IMO Number	Call Sign	Service
CCL 22	1191600			Tank Barge

Hailing Port	Hull Material	Horsepower	Propulsion
BATON ROUGE, LA	Steel		
UNITED STATES			

Place Built	Delivery Date	Keel Laid Date	Gross Tons	Net Tons	DWT	Length
GALVESTON, TX	23Mar2007	15Dec2006	R-735	R-735		R-200.0
UNITED STATES			-	-		10

Owner	Operator
CHEM CARRIERS LLC 1237 HIGHWAY 75 SUNSHINE, LA 70780 UNITED STATES	CHEM CARRIERS LLC 1237 HIGHWAY 75 SUNSHINE, LA 70780 UNITED STATES

This vessel must be manned with the following licensed and unlicensed Personnel. Included in which there must be 0 Certified Lifeboatmen, 0 Certified Tankermen, 0 HSC Type Rating, and 0 GMDSS Operators.

0 Masters	0 Licensed Mates	0 Chief Engineers	0 Oilers
0 Chief Mates	0 First Class Pilots	0 First Assistant Engineers	
0 Second Mates	0 Radio Officers	0 Second Assistant Engineers	
0 Third Mates	0 Able Seamen	0 Third Assistant Engineers	
0 Master First Class Pilot	0 Ordinary Seamen	0 Licensed Engineers	
0 Mate First Class Pilots	0 Deckhands	0 Qualified Member Engineer	

In addition, this vessel may carry 0 Passengers, 0 Other Persons in crew, 0 Persons in addition to crew, and no Others. Total Persons allowed: 0

Route Permitted And Conditions Of Operation:
---Lakes, Bays, and Sounds---

Also, in fair weather only, coastwise, not more than twelve (12) miles from shore between St. Marks and Carrabelle, Florida.

This vessel has been granted a fresh water service examination interval in accordance with 46 CFR Table 31.10-21(b); if this vessel is operated in salt water more than six (6) months in any twelve (12) month period, the vessel must be inspected using salt water intervals and the cognizant OCMI notified in writing as soon as this change in status occurs.

SEE NEXT PAGE FOR ADDITIONAL CERTIFICATE INFORMATION

With this Inspection for Certification having been completed at Baton Rouge, LA, UNITED STATES, the Officer in Charge, Marine Inspection, New Orleans, LA certified the vessel, in all respects, is in conformity with the applicable vessel inspection laws and the rules and regulations prescribed thereunder.

Annual/Periodic/Re-Inspection				This certificate issued by: <i>P. J. Raneri</i> P. J. RANERI LCDR, USCG, by direction
Date	Zone	A/P/R	Signature	
5 APR 23	BATU	A	<i>[Signature]</i>	Officer in Charge, Marine Inspection New Orleans, LA
29 MAY 24	SHG	A	<i>[Signature]</i>	
22 MAY 25	Seaboard	P	<i>[Signature]</i>	
				Inspection Zone



Certificate of Inspection

Vessel Name: CCL 22

---Hull Exams---

Exam Type	Next Exam	Last Exam	Prior Exam
DryDock	31Mar2027	14Mar2017	27Mar2007
Internal Structure	31Mar2027	10Mar2022	14Mar2017

--- Liquid/Gas/Solid Cargo Authority/Conditions ---

Authorization: GRADE "A" AND LOWER AND SPECIFIED HAZARDOUS CARGOES.

Total Capacity	Units	Highest Grade Type	Part151 Regulated	Part153 Regulated	Part154 Regulated
11430	Barrels	A	Yes	No	No

Hazardous Bulk Solids Authority

Not Authorized

Loading Constraints - Structural

Tank Location Description	Max Cargo Weight per Tank (short tons)	Maximum Density (lbs/gal)
1 C/L	649	15.00
2 C/L	761	15.00
3 C/L	676	15.00

Loading Constraints - Stability

Hull Type	Maximum Load (short tons)	Maximum Draft (ft/in)	Max Density (lbs/gal)	Route Description
I	1429	8ft 9in	15.00	LBS
II	1519	9ft 2in	15.00	LBS
III	1735	10ft 2in	15.00	LBS
III	1807	10ft 6in	13.50	LBS
III	1825	10ft 7in	12.80	LBS
III	1915	11ft 0in	15.00	R
III	1969	11ft 3in	13.50	R
III	1987	11ft 4in	12.80	R

Conditions Of Carriage

Vapor Control Authorization

Only those cargoes named in the vessel's Cargo Authority Attachment (CAA), serial #C2-0701708, dated 29MAY07, may be carried and then only in the tanks indicated. In accordance with 46 CFR Part 39, excluding part 39.40, this vessel's vapor control system has been inspected to the plans approved by Marine Safety Center letters serial #C2-0602834, dated 02OCT06 and serial #C1-0603571, dated 04DEC06, and found acceptable for collection of bulk liquid cargo vapors annotated with "Yes" in the CAA's VCS column

When the vessel is carrying cargoes containing greater than 0.5% benzene, the person in charge is responsible for ensuring the provisions of 46 US Code of Federal Regulations Part 197, Subpart C are applied.

--- Inspection Status ---



Certificate of Inspection

Vessel Name: CCL 22

Cargo Tanks

Tank Id	Internal Exam			External Exam		
	Previous	Last	Next	Previous	Last	Next
1 C/L	27Mar2007	14Mar2017	31Mar2027	-	-	-
2 C/L	27Mar2007	14Mar2017	31Mar2027	-	-	-
3 C/L	27Mar2007	14Mar2017	31Mar2027	-	-	-

Hydro Test

Tank Id	Safety Valves		Previous	Last	Next
	Previous	Last			
1 C/L	-	-	-	-	-
2 C/L	-	-	-	-	-
3 C/L	-	-	-	-	-

---Conditional Portable Fire Extinguisher Requirements---

Required Only During Transfer of Cargo or Operation of Barge Machinery

--- Fire Fighting Equipment ---

Number of Fireman Outfits - 0

Fire Extinguishers - Hand portable and semi-portable

Quantity	Class Type
2	40-B

END



Certificate of Inspection

Cargo Authority Attachment

Vessel Name: **CCL 22**
Official #: 1191600

Shipyard: Southwest Shipyard
Hull #: 9541

46 CFR 151 Tank Group Characteristics

Tank Group Information		Cargo Identification			Tanks			Cargo Transfer		Environmental Control		Fire Protection Provided	Special Requirements		Elec Haz	Temp Cont		
Tnk Grp	Tanks in Group	Density	Press.	Temp.	Hull Typ	Cargo Seg Tank	Type	Vent	Gauge	Pipe Class	Cont	Tanks	Handling Space	General	Materials of Construction			
A	1,2,3	15	Atmos.	Amb.	I	1ii	Integral Gravity	PV	Closed	II	G-1	NR	NA	Portable	.50-60, .50-70(a), .50-70(b), .50-73, .50-81(a), .50-81(b),	55-1(b), (c), (e), (f), (j), 56-1(a), (b), (c), (d), (e), (f), (g),	NR	No

- Notes: 1. Under Environmental Control, Tanks, NR means that the tank group is suitable only for those cargoes which require no environmental control in the cargo tanks.
2. Under Environmental Control, Handling Space, NR means that the tank group is suitable only for those cargoes which require no environmental control in the cargo handling space. NA means that the vessel does not have a cargo control space, and this requirement is not applied.
3. Under Electrical Hazard Class, NA means that the tank group is suitable only for those cargoes which have no electrical hazard class requirement. NR means that the vessel has no electrical equipment located in a hazardous location.

List of Authorized Cargoes

Cargo Identification							Conditions of Carriage				
Name	Chem Code	Compat Group No	Sub Chapter	Grade	Hull Type	Tank Group	Vapor Recovery		Special Requirements in 46 CFR 151 General and Mat'ls of	Insp. Period	
							App'd (Y or N)	VCS Category			

Authorized Subchapter O Cargoes

Acetonitrile	ATN	37	O	C	III	A	Yes	3	No	G
Acrylonitrile	ACN	15 ²	O	C	II	A	Yes	4	.50-70(a), .55-1(e)	G
Adiponitrile	ADN	37	O	E	II	A	Yes	1	No	G
Alkyl(C7-C9) nitrates	AKN	34 ²	O	NA	III	A	No	N/A	.50-81, .50-86	G
Aminoethylethanolamine	AEE	8	O	E	III	A	Yes	1	.55-1(b)	G
Ammonium bisulfite solution (70% or less)	ABX	43 ²	O	NA	III	A	No	N/A	.50-73, .56-1(a), (b), (c)	G
Ammonium hydroxide (28% or less NH3)	AMH	6	O	NA	III	A	No	N/A	.56-1(a), (b), (c), (f), (g)	G
Anthracene oil (Coal tar fraction)	AHO	33	O	NA	II	A	No	N/A	No	G
Benzene	BNZ	32	O	C	III	A	Yes	1	.50-60	G
Benzene or hydrocarbon mixtures (having 10% Benzene or more)	BHB	32 ²	O	C	III	A	Yes	1	.50-60	G
Benzene or hydrocarbon mixtures (containing Acetylene and 10% Benzene or more)	BHA	32 ²	O	C	III	A	Yes	1	.50-60, .56-1(b), (d), (f), (g)	G
Benzene, Toluene, Xylene mixtures (10% Benzene or more)	BTX	32	O	B/C	III	A	Yes	1	.50-60	G
Butyl acrylate (all isomers)	BAR	14	O	D	III	A	Yes	2	.50-70(a), .50-81(a), (b)	G
Butyl methacrylate	BMH	14	O	D	III	A	Yes	2	.50-70(a), .50-81(a), (b)	G
Butyraldehyde (all isomers)	BAE	19	O	C	III	A	Yes	1	.55-1(h)	G
Camphor oil (light)	CPO	18	O	D	II	A	No	N/A	No	G
Carbon tetrachloride	CBT	36	O	NA	III	A	No	N/A	No	G
Caustic potash solution	CPS	5 ²	O	NA	III	A	No	N/A	.50-73, .55-1(j)	G
Caustic soda solution	CSS	5 ²	O	NA	III	A	No	N/A	.50-73, .55-1(j)	G
Chemical Oil (refined, containing phenolics)	COD	21	O	E	II	A	No	N/A	.50-73	G
Chlorobenzene	CRB	36	O	D	III	A	Yes	1	No	G
Chloroform	CRF	36	O	NA	III	A	Yes	3	No	G
Coal tar naphtha solvent	NCT	33	O	D	III	A	Yes	1	.50-73	G
Creosote	CCW	21 ²	O	E	III	A	Yes	1	No	G
Cresols (all isomers)	CRS	21	O	E	III	A	Yes	1	No	G
Cresylate spent caustic	CSC	5	O	NA	III	A	No	N/A	.50-73, .55-1(b)	G
Cresylic acid tar	CRX		O	E	III	A	Yes	1	.55-1(f)	G
Crotonaldehyde	CTA	19 ²	O	C	II	A	Yes	4	.55-1(h)	G
Crude hydrocarbon feedstock (containing Butyraldehydes and Ethylpropyl acrolein)	CHG		O	C	III	A	No	N/A	No	G
Cyclohexanone	CCH	18	O	D	III	A	Yes	1	.56-1(a), (b)	G
Cyclohexanone, Cyclohexanol mixture	CYX	18 ²	O	E	III	A	Yes	1	.56-1 (b)	G
Cyclohexylamine	CHA	7	O	D	III	A	Yes	1	.56-1(a), (b), (c), (g)	G
Cyclopentadiene, Styrene, Benzene mixture	CSB	30	O	D	III	A	Yes	1	.50-60, .56-1(b)	G
iso-Decyl acrylate	IAI	14	O	E	III	A	Yes	2	.50-70(a), .50-81(a), (b), .55-1(c)	G

*** This document is only valid when attached to, and referenced by a current, valid Certificate of Inspection. ***



Certificate of Inspection

Cargo Authority Attachment

Vessel Name: **CCL 22**
Official #: 1191600

Page 2 of 8

Shipyard: Southwest Shipyard
Hull #: 9541

Cargo Identification							Conditions of Carriage				
Name	Chem Code	Compat Group No	Sub Chapter	Grade	Hull Type	Tank Group	Vapor Recovery		Special Requirements in 46 CFR 151 General and Mat'ls of	Insp Period	
							App'd (Y or N)	VCS Category			
Dichlorobenzene (all isomers)	DBX	36	O	E	III	A	Yes	3	.56-1(a), (b)	G	
1,1-Dichloroethane	DCH	36	O	C	III	A	Yes	1	No	G	
2,2'-Dichloroethyl ether	DEE	41	O	D	II	A	Yes	1	.55-1(f)	G	
Dichloromethane	DCM	36	O	NA	III	A	No	N/A	No	G	
2,4-Dichlorophenoxyacetic acid, diethanolamine salt solution	DDE	43	O	E	III	A	No	N/A	.56-1(a), (b), (c), (g)	G	
2,4-Dichlorophenoxyacetic acid, dimethylamine salt solution	DAD	0 ^{1,2}	O	A	III	A	No	N/A	.56-1(a), (b), (c), (g)	G	
2,4-Dichlorophenoxyacetic acid, triisopropanolamine salt solution	DTI	43 ²	O	E	III	A	No	N/A	.56-1(a), (b), (c), (g)	G	
1,1-Dichloropropane	DPB	36	O	C	III	A	Yes	3	No	G	
1,2-Dichloropropane	DPP	36	O	C	III	A	Yes	3	No	G	
1,3-Dichloropropane	DPC	36	O	C	III	A	Yes	3	No	G	
1,3-Dichloropropene	DPU	15	O	D	II	A	Yes	4	No	G	
Dichloropropene, Dichloropropane mixtures	DMX	15	O	C	II	A	Yes	1	No	G	
Diethanolamine	DEA	8	O	E	III	A	Yes	1	.55-1(c)	G	
Diethylamine	DEN	7	O	C	III	A	Yes	3	.55-1(c)	G	
Diethylenetriamine	DET	7 ²	O	E	III	A	Yes	1	.55-1(c)	G	
Diisobutylamine	DBU	7	O	D	III	A	Yes	3	.55-1(c)	G	
Diisopropanolamine	DIP	8	O	E	III	A	Yes	1	.55-1(c)	G	
Diisopropylamine	DIA	7	O	C	II	A	Yes	3	.55-1(c)	G	
N,N-Dimethylacetamide	DAC	10	O	E	III	A	Yes	3	.56-1(b)	G	
Dimethylethanolamine	DMB	8	O	D	III	A	Yes	1	.56-1(b), (c)	G	
Dimethylformamide	DMF	10	O	D	III	A	Yes	1	.55-1(e)	G	
Di-n-propylamine	DNA	7	O	C	II	A	Yes	3	.55-1(c)	G	
Dodecyl dimethylamine, Tetradecyl dimethylamine mixture	DOT	7	O	E	III	A	No	N/A	.56-1(b)	G	
Dodecyl diphenyl ether disulfonate solution	DOS	43	O	#	II	A	No	N/A	No	G	
EE Glycol Ether Mixture	EEG	40	O	D	III	A	No	N/A	No	G	
Ethanolamine	MEA	8	O	E	III	A	Yes	1	.55-1(c)	G	
Ethyl acrylate	EAC	14	O	C	III	A	Yes	2	.50-70(a), .50-81(a), (b)	G	
Ethylamine solution (72% or less)	EAN	7	O	A	II	A	Yes	6	.55-1(b)	G	
N-Ethylbutylamine	EBA	7	O	D	III	A	Yes	3	.55-1(b)	G	
N-Ethylcyclohexylamine	ECC	7	O	D	III	A	Yes	1	.55-1(b)	G	
Ethylene cyanohydrin	ETC	20	O	E	III	A	Yes	1	No	G	
Ethylenediamine	EDA	7 ²	O	D	III	A	Yes	1	.55-1(c)	G	
Ethylene dichloride	EDC	36 ²	O	C	III	A	Yes	1	No	G	
Ethylene glycol hexyl ether	EGH	40	O	E	III	A	No	N/A	No	G	
Ethylene glycol monoalkyl ethers	EGC	40	O	D/E	III	A	Yes	1	No	G	
Ethylene glycol propyl ether	EGP	40	O	E	III	A	Yes	1	No	G	
2-Ethylhexyl acrylate	EAI	14	O	E	III	A	Yes	2	.50-70(a), .50-81(a), (b)	G	
Ethyl methacrylate	ETM	14	O	D/E	III	A	Yes	2	.50-70(a)	G	
2-Ethyl-3-propylacrolein	EPA	19 ²	O	E	III	A	Yes	1	No	G	
Formaldehyde solution (37% to 50%)	FMS	19 ²	O	D/E	III	A	Yes	1	.55-1(h)	G	
Furfural	FFA	19	O	D	III	A	Yes	1	.55-1(h)	G	
Glutaraldehyde solution (50% or less)	GTA	19	O	NA	III	A	No	N/A	No	G	
Hexamethylenediamine solution	HMC	7	O	E	III	A	Yes	1	.55-1(c)	G	
Hexamethyleneimine	HMI	7	O	C	II	A	Yes	1	.56-1(b), (c)	G	
Hydrocarbon 5-9	HFN		O	C	III	A	Yes	1	.50-70(a), .50-81(a), (b)	G	
Isoprene	IPR	30	O	A	III	A	No	N/A	.50-70(a), .50-81(a), (b)	G	
Isoprene, Pentadiene mixture	IPN		O	B	III	A	No	N/A	.50-70(a), .55-1(c)	G	
Kraft pulping liquors (free alkali content 3% or more)(including: Black, Green, or White liquor)	KPL	5	O	NA	III	A	No	N/A	.50-73, .56-1(a), (c), (g)	G	
Mesityl oxide	MSO	18 ²	O	D	III	A	Yes	1	No	G	

*** This document is only valid when attached to, and referenced by a current, valid Certificate of Inspection. ***



Certificate of Inspection

Cargo Authority Attachment

Vessel Name: **CCL 22**
Official #: 1191600

Shipyard: Southwest Shipyard
Hull #: 9541

Cargo Identification						Conditions of Carriage					
Name	Chem Code	Compat Group No	Sub Chapter	Grade	Hull Type	Tank Group	Vapor Recovery		Special Requirements in 46 CFR 151 General and Mat'ls of	Insp. Period	
							App'd (Y or N)	VCS Category			
Methyl acrylate	MAM	14	O	C	III	A	Yes	2	50-70(a), 50-81(a), (b)	G	
Methylcyclopentadiene dimer	MCK	30	O	C	III	A	Yes	1	No	G	
Methyl diethanolamine	MDE	8	O	E	III	A	Yes	1	56-1(b), (c)	G	
2-Methyl-5-ethylpyridine	MEP	9	O	E	III	A	Yes	1	55-1(e)	G	
Methyl methacrylate	MMM	14	O	C	III	A	Yes	2	50-70(a), 50-81(a), (b)	G	
2-Methylpyridine	MPR	9	O	D	III	A	Yes	3	55-1(c)	G	
alpha-Methylstyrene	MSR	30	O	D	III	A	Yes	2	50-70(a), 50-81(a), (b)	G	
Morpholine	MPL	7 ²	O	D	III	A	Yes	1	55-1(c)	G	
1- or 2-Nitropropane	NPM	42	O	D	III	A	Yes	1	50-81	G	
Pentachloroethane	PCE	36	O	NA	III	A	No	N/A	No	G	
1,3-Pentadiene	PDE	30	O	A	III	A	Yes	7	50-70(a), 50-81	G	
Perchloroethylene	PER	36	O	NA	III	A	No	N/A	No	G	
Polyethylene polyamines	PEB	7 ²	O	E	III	A	Yes	1	55-1(e)	G	
iso-Propanolamine	MPA	8	O	E	III	A	Yes	1	55-1(c)	G	
Propanolamine (iso-, n-)	PAX	8	O	E	III	A	Yes	1	56-1(b), (c)	G	
iso-Propylamine	IPP	7	O	A	II	A	Yes	5	55-1(c)	G	
Pyridine	PRD	9	O	C	III	A	Yes	1	55-1(e)	G	
Sodium acetate, Glycol, Water mixture (3% or more Sodium Hydroxide)	SAP		O		III	A	No	N/A	50-73, 55-1(j)	G	
Sodium aluminate solution (45% or less)	SAU	5	O	NA	III	A	No	N/A	50-73, 56-1(a), (b), (c)	G	
Sodium chlorate solution (50% or less)	SDD	0 ^{1,2}	O	NA	III	A	No	N/A	50-73	G	
Sodium hypochlorite solution (20% or less)	SHQ	5	O	NA	III	A	No	N/A	50-73, 56-1(a), (b)	G	
Sodium sulfide, hydrosulfide solution (H2S 15 ppm or less)	SSH	0 ^{1,2}	O	NA	III	A	Yes	1	50-73, 55-1(b)	G	
Sodium sulfide, hydrosulfide solution (H2S greater than 15 ppm but less than 200 ppm)	SSI	0 ^{1,2}	O	NA	III	A	No	N/A	50-73, 55-1(b)	G	
Sodium sulfide, hydrosulfide solution (H2S greater than 200 ppm)	SSJ	0 ^{1,2}	O	NA	II	A	No	N/A	50-73, 55-1(b)	G	
Styrene (crude)	STX		O	D	III	A	Yes	2	No	G	
Styrene monomer	STY	30	O	D	III	A	Yes	2	50-70(a), 50-81(a), (b)	G	
1,1,2,2-Tetrachloroethane	TEC	36	O	NA	III	A	No	N/A	No	G	
Tetraethylenepentamine	TTP	7	O	E	III	A	Yes	1	55-1(c)	G	
Tetrahydrofuran	THF	41	O	C	III	A	Yes	1	50-70(b)	G	
Toluenediamine	TDA	9	O	E	II	A	No	N/A	50-73, 56-1(a), (b), (c), (g)	G	
1,2,4-Trichlorobenzene	TCB	36	O	E	III	A	Yes	1	No	G	
1,1,2-Trichloroethane	TCM	36	O	NA	III	A	Yes	1	50-73, 56-1(a)	G	
Trichloroethylene	TCL	36 ²	O	NA	III	A	Yes	1	No	G	
1,2,3-Trichloropropane	TCN	36	O	E	II	A	Yes	3	50-73, 56-1(a)	G	
Triethanolamine	TEA	8 ²	O	E	III	A	Yes	1	55-1(b)	G	
Triethylamine	TEN	7	O	C	II	A	Yes	3	55-1(e)	G	
Triethylenetetramine	TET	7 ²	O	E	III	A	Yes	1	55-1(b)	G	
Triphenylborane (10% or less), caustic soda solution	TPB	5	O	NA	III	A	No	N/A	56-1(a), (b), (c)	G	
Trisodium phosphate solution	TSP	5	O	NA	III	A	No	N/A	50-73, 56-1(a), (c)	G	
Urea, Ammonium nitrate solution (containing more than 2% NH3)	UAS	6	O	NA	III	A	No	N/A	56-1(b)	G	
Vanillin black liquor (free alkali content, 3% or more)	VBL	5	O	NA	III	A	No	N/A	50-73, 56-1(a), (c), (g)	G	
Vinyl acetate	VAM	13	O	C	III	A	Yes	2	50-70(a), 50-81(a), (b)	G	
Vinyl neodecanate	VND	13	O	E	III	A	No	N/A	50-70(a), 50-81(a), (b)	G	
Vinyltoluene	VNT	13	O	D	III	A	Yes	2	50-70(a), 50-81, 56-1(a), (b), (c), (f)	G	

Subchapter D Cargoes Authorized for Vapor Control

Acetone	ACT	18 ²	D	C	A	Yes	1
Acetophenone	ACP	18	D	E	A	Yes	1

*** This document is only valid when attached to, and referenced by a current, valid Certificate of Inspection. ***



Certificate of Inspection

Cargo Authority Attachment

Vessel Name: **CCL 22**
 Official #: 1191600

Shipyard: Southwest Shipyard
 Hull #: 9541

Name	Cargo Identification						Conditions of Carriage				
	Chem Code	Compat Group No	Sub Chapter	Grade	Hull Type	Tank Group	Vapor Recovery		Special Requirements in 46 CFR 151 General and Mat'ls of	Insp. Period	
						App'd (Y or N)	VCS Category				
Alcohol(C12-C16) poly(1-6)ethoxylates	APU	20	D	E		A	Yes	1			
Alcohol(C6-C17)(secondary) poly(7-12)ethoxylates	AEB	20	D	E		A	Yes	1			
Amyl acetate (all isomers)	AEC	34	D	D		A	Yes	1			
Amyl alcohol (iso-, n-, sec-, primary)	AAI	20	D	D		A	Yes	1			
Benzyl alcohol	BAL	21	D	E		A	Yes	1			
Brake fluid base mixtures (containing Poly(2-8)alkylene(C2-C3) glycols, Polyalkylene(C2-C10) glycol monoalkyl(C1-C4) ethers, and their borate esters)	BFX	20	D	E		A	Yes	1			
Butyl acetate (all isomers)	BAX	34	D	D		A	Yes	1			
Butyl alcohol (iso-)	IAL	20 ²	D	D		A	Yes	1			
Butyl alcohol (n-)	BAN		D	D		A	Yes	1			
Butyl alcohol (sec-)	BAS		D	C		A	Yes	1			
Butyl alcohol (tert-)	BAT		D	C		A	Yes	1			
Butyl benzyl phthalate	BPH	34	D	E		A	Yes	1			
Butyl toluene	BUE	32	D	D		A	Yes	1			
Caprolactam solutions	CLS	22	D	E		A	Yes	1			
Cyclohexane	CHX	31	D	C		A	Yes	1			
Cyclohexanol	CHN	20	D	E		A	Yes	1			
1,3-Cyclopentadiene dimer (molten)	CPD	30	D	D/E		A	Yes	2			
p-Cymene	CMP	32	D	D		A	Yes	1			
iso-Decaldehyde	IDA	19	D	E		A	Yes	1			
n-Decaldehyde	DAL	19	D	E		A	Yes	1			
Decene	DCE	30	D	D		A	Yes	1			
Decyl alcohol (all isomers)	DAX	20 ²	D	E		A	Yes	1			
n-Decylbenzene, see Alkyl(C9+)benzenes	DBZ	32	D	E		A	Yes	1			
Diacetone alcohol	DAA	20 ²	D	D		A	Yes	1			
ortho-Dibutyl phthalate	DPA	34	D	E		A	Yes	1			
Diethylbenzene	DEB	32	D	D		A	Yes	1			
Diethylene glycol	DEG	40 ²	D	E		A	Yes	1			
Diisobutylene	DBL	30	D	C		A	Yes	1			
Diisobutyl ketone	DIK	18	D	D		A	Yes	1			
Diisopropylbenzene (all isomers)	DIX	32	D	E		A	Yes	1			
Dimethyl phthalate	DTL	34	D	E		A	Yes	1			
Dioctyl phthalate	DOP	34	D	E		A	Yes	1			
Dipentene	DPN	30	D	D		A	Yes	1			
Diphenyl	DIL	32	D	D/E		A	Yes	1			
Diphenyl, Diphenyl ether mixtures	DDO	33	D	E		A	Yes	1			
Diphenyl ether	DPE	41	D	{E}		A	Yes	1			
Dipropylene glycol	DPG	40	D	E		A	Yes	1			
Distillates: Flashed feed stocks	DFF	33	D	E		A	Yes	1			
Distillates: Straight run	DSR	33	D	E		A	Yes	1			
Dodecene (all isomers)	DOZ	30	D	D		A	Yes	1			
Dodecylbenzene, see Alkyl(C9+)benzenes	DDB	32	D	E		A	Yes	1			
2-Ethoxyethyl acetate	EEA	34	D	D		A	Yes	1			
Ethoxy triglycol (crude)	ETG	40	D	E		A	Yes	1			
Ethyl acetate	ETA	34	D	C		A	Yes	1			
Ethyl acetoacetate	EAA	34	D	E		A	Yes	1			
Ethyl alcohol	EAL	20 ²	D	C		A	Yes	1			
Ethylbenzene	ETB	32	D	C		A	Yes	1			
Ethyl butanol	EBT	20	D	D		A	Yes	1			
Ethyl tert-butyl ether	EBE	41	D	C		A	Yes	1			

*** This document is only valid when attached to, and referenced by a current, valid Certificate of Inspection. ***



Department of Homeland Security
United States Coast Guard

Serial #: C2-0701708
 Dated: 29-May-07

Certificate of Inspection

Cargo Authority Attachment

Vessel Name: **CCL 22**
 Official #: 1191600

Page 5 of 8

Shipyard: Southwest Shipyard
 Hull #: 9541

Cargo Identification						Conditions of Carriage				
Name	Chem Code	Compat Group No	Sub Chapter	Grade	Hull Type	Tank Group	Vapor Recovery		Special Requirements in 46 CFR 151 General and Mat'l's of	Insp. Period
							App'd (Y or N)	VCS Category		
Ethyl butyrate	EBR	34	D	D		A	Yes	1		
Ethyl cyclohexane	ECY	31	D	D		A	Yes	1		
Ethylene glycol	EGL	20 ²	D	E		A	Yes	1		
Ethylene glycol butyl ether acetate	EMA	34	D	E		A	Yes	1		
Ethylene glycol diacetate	EGY	34	D	E		A	Yes	1		
Ethylene glycol phenyl ether	EPE	40	D	E		A	Yes	1		
Ethyl-3-ethoxypropionate	EEP	34	D	D		A	Yes	1		
2-Ethylhexanol	EHX	20	D	E		A	Yes	1		
Ethyl propionate	EPR	34	D	C		A	Yes	1		
Ethyl toluene	ETE	32	D	D		A	Yes	1		
Formamide	FAM	10	D	E		A	Yes	1		
Furfuryl alcohol	FAL	20 ²	D	E		A	Yes	1		
Gasoline blending stocks: Alkylates	GAK	33	D	A/C		A	Yes	1		
Gasoline blending stocks: Reformates	GRF	33	D	A/C		A	Yes	1		
Gasolines: Automotive (containing not over 4.23 grams lead per gallon)	GAT	33	D	C		A	Yes	1		
Gasolines: Aviation (containing not over 4.86 grams of lead per gallon)	GAV	33	D	C		A	Yes	1		
Gasolines: Casinghead (natural)	GCS	33	D	A/C		A	Yes	1		
Gasolines: Polymer	GPL	33	D	A/C		A	Yes	1		
Gasolines: Straight run	GSR	33	D	A/C		A	Yes	1		
Glycerine	GCR	20 ²	D	E		A	Yes	1		
Heptane (all isomers), see Alkanes (C6-C9) (all isomers)	HMX	31	D	C		A	Yes	1		
Heptanoic acid	HEP	4	D	E		A	Yes	1		
Heptanol (all isomers)	HTX	20	D	D/E		A	Yes	1		
Heptene (all isomers)	HPX	30	D	C		A	Yes	2		
Heptyl acetate	HPE	34	D	E		A	Yes	1		
Hexane (all isomers), see Alkanes (C6-C9)	HXS	31 ²	D	B/C		A	Yes	1		
Hexanoic acid	HXO	4	D	E		A	Yes	1		
Hexanol	HXN	20	D	D		A	Yes	1		
Hexene (all isomers)	HEX	30	D	C		A	Yes	2		
Hexylene glycol	HXG	20	D	E		A	Yes	1		
Isophorone	IPH	18 ²	D	E		A	Yes	1		
Jet fuel: JP-4	JPF	33	D	E		A	Yes	1		
Jet fuel: JP-5 (kerosene, heavy)	JPV	33	D	D		A	Yes	1		
Kerosene	KRS	33	D	D		A	Yes	1		
Methyl acetate	MTT	34	D	D		A	Yes	1		
Methyl alcohol	MAL	20 ²	D	C		A	Yes	1		
Methylamyl acetate	MAC	34	D	D		A	Yes	1		
Methylamyl alcohol	MAA	20	D	D		A	Yes	1		
Methyl amyl ketone	MAK	18	D	D		A	Yes	1		
Methyl tert-butyl ether	MBE	41 ²	D	C		A	Yes	1		
Methyl butyl ketone	MBK	18	D	C		A	Yes	1		
Methyl butyrate	MBU	34	D	C		A	Yes	1		
Methyl ethyl ketone	MEK	18 ²	D	C		A	Yes	1		
Methyl heptyl ketone	MHK	18	D	D		A	Yes	1		
Methyl isobutyl ketone	MIK	18 ²	D	C		A	Yes	1		
Methyl naphthalene (molten)	MNA	32	D	E		A	Yes	1		
Mineral spirits	MNS	33	D	D		A	Yes	1		
Myrcene	MRE	30	D	D		A	Yes	1		
Naphtha: Heavy	NAG	33	D	#		A	Yes	1		

*** This document is only valid when attached to, and referenced by a current, valid Certificate of Inspection. ***



Certificate of Inspection

Cargo Authority Attachment

Vessel Name: **CCL 22**
 Official #: 1191600

Page 6 of 8

Shipyard: Southwest Shipyard
 Hull #: 9541

Cargo Identification							Conditions of Carriage				
Name	Chem Code	Compat Group No	Sub Chapter	Grade	Hull Type	Tank Group	Vapor Recovery		Special Requirements in 46 CFR 151 General and Mat'l's of	Insp. Period	
							App'd (Y or N)	VCS Category			
Naphtha: Petroleum	PTN	33	D	#		A	Yes	1			
Naphtha: Solvent	NSV	33	D	D		A	Yes	1			
Naphtha: Stoddard solvent	NSS	33	D	D		A	Yes	1			
Naphtha: Varnish makers and painters (75%)	NVM	33	D	C		A	Yes	1			
Nonane (all isomers), see Alkanes (C6-C9)	NAX	31	D	D		A	Yes	1			
Nonene (all isomers)	NON	30	D	D		A	Yes	2			
Nonyl alcohol (all isomers)	NNS	20 ²	D	E		A	Yes	1			
Nonyl phenol	NNP	21	D	E		A	Yes	1			
Nonyl phenol poly(4+)ethoxylates	NPE	40	D	E		A	Yes	1			
Octane (all isomers), see Alkanes (C6-C9)	OAX	31	D	C		A	Yes	1			
Octanoic acid (all isomers)	OAY	4	D	E		A	Yes	1			
Octanol (all isomers)	OCX	20 ²	D	E		A	Yes	1			
Octene (all isomers)	OTX	30	D	C		A	Yes	2			
Oil, fuel: No. 2	OTW	33	D	D/E		A	Yes	1			
Oil, fuel: No. 2-D	OTD	33	D	D		A	Yes	1			
Oil, fuel: No. 4	OFR	33	D	D/E		A	Yes	1			
Oil, fuel: No. 5	OFV	33	D	D/E		A	Yes	1			
Oil, fuel: No. 6	OSX	33	D	E		A	Yes	1			
Oil, misc: Crude	OIL	33	D	C/D		A	Yes	1			
Oil, misc: Diesel	ODS	33	D	D/E		A	Yes	1			
Oil, misc: Lubricating	OLB	33	D	E		A	Yes	1			
Oil, misc: Residual	ORL	33	D	E		A	Yes	1			
Oil, misc: Turbine	OTB	33	D	E		A	Yes	1			
alpha-Pinene	PIO	30	D	D		A	Yes	1			
beta-Pinene	PIP	30	D	D		A	Yes	1			
Poly(2-8)alkylene glycol monoalkyl(C1-C6) ether	PAG	40	D	E		A	Yes	1			
Poly(2-8)alkylene glycol monoalkyl(C1-C6) ether acetate	PAF	34	D	E		A	Yes	1			
Polybutene	PLB	30	D	E		A	Yes	1			
Polypropylene glycol	PGC	40	D	E		A	Yes	1			
iso-Propyl acetate	IAC	34	D	C		A	Yes	1			
n-Propyl acetate	PAT	34	D	C		A	Yes	1			
iso-Propyl alcohol	IPA	20 ²	D	C		A	Yes	1			
n-Propyl alcohol	PAL	20 ²	D	C		A	Yes	1			
Propylbenzene (all isomers)	PBY	32	D	D		A	Yes	1			
iso-Propylcyclohexane	IPX	31	D	D		A	Yes	1			
Propylene glycol	PPG	20 ²	D	E		A	Yes	1			
Propylene glycol methyl ether acetate	PGN	34	D	D		A	Yes	1			
Propylene tetramer	PTT	30	D	D		A	Yes	1			
Sulfolane	SFL	39	D	E		A	Yes	1			
Tetraethylene glycol	TTG	40	D	E		A	Yes	1			
Tetrahydronaphthalene	THN	32	D	E		A	Yes	1			
Toluene	TOL	32	D	C		A	Yes	1			
Tricresyl phosphate (less than 1% of the ortho isomer)	TCP	34	D	E		A	Yes	1			
Triethylbenzene	TEB	32	D	E		A	Yes	1			
Triethylene glycol	TEG	40	D	E		A	Yes	1			
Triethyl phosphate	TPS	34	D	E		A	Yes	1			
Trimethylbenzene (all isomers)	TRE	32	D	{D}		A	Yes	1			
Trixylenyl phosphate	TRP	34	D	E		A	Yes	1			
Undecene	UDC	30	D	D/E		A	Yes	1			
1-Undecyl alcohol	UND	20	D	E		A	Yes	1			

*** This document is only valid when attached to, and referenced by a current, valid Certificate of Inspection. ***



Certificate of Inspection

Cargo Authority Attachment

Vessel Name: CCL 22
Official #: 1191600

Page 7 of 8

Shipyard: Southwest Shipyard
Hull #: 9541

Cargo Identification						Conditions of Carriage				
Name	Chem Code	Compat Group No	Sub Chapter	Grade	Hull Type	Tank Group	Vapor Recovery		Special Requirements in 46 CFR 151 General and Mat'ls of	Insp. Period
							App'd (Y or N)	VCS Category		
Xylenes (ortho-, meta-, para-)	XLX	32	D	D		A	Yes	1		



Certificate of Inspection

Cargo Authority Attachment

Vessel Name: CCL 22
Official #: 1191600

Page 8 of 8

Shipyard: Southwest Shi
Hull #: 9541

Explanation of terms & symbols used in the Table:

Cargo Identification

Name	The proper shipping name as listed in 46 CFR Table 30.25-1, 46 CFR Table 151.05, and 46 CFR Part 153 Table 2.
Chem Code none	The three letter designation assigned to the cargo in the Chemical Hazards Response Information System (CHRIS) Manual. Certain mixtures of cargoes may not have a CHRIS Code assigned.
Compatibility Group No.	The cargo reactive group number assigned for compatibility determinations in 46 CFR Part 150 Tables I and II. In accordance with 46 CFR 150.130, the Person-in-Charge of the barge is responsible for ensuring that the compatibility requirements of 46 CFR Part 150 are met. Cargoes must be checked for compatibility using the figures, tables, and appendices of 46 CFR 150 in conjunction with the assigned reactive group number.
Note 1	Because of the very high reactivity or unusual conditions of carriage or potential compatibility problems, this product is not assigned to a specific group in the Compatibility Chart. For additional compatibility information, contact Commandant (CG-3PSO-3), U.S. Coast Guard, 2100 Second Street, SW, Washington, DC 20593-0001. Telephone (202) 372-1425.
Note 2	See Appendix I to 46 CFR Part 150 - exceptions to the compatibility chart.
Subchapter Subchapter D Subchapter O Note 3	The subchapter in Title 46 Code of Federal Regulations under which the cargo has been classified. Those flammable and combustible liquids listed in 46 CFR Table 30.25-1. Those hazardous cargoes listed in 46 CFR Table 151.05 and 46 CFR Part 153 Table 2. Those cargoes listed in 46 CFR Part 153 Table 2 are non-regulated cargoes when carried in bulk on non-oceangoing barges.
Grade	The cargo classification assigned to each flammable or combustible liquid. Grades inside of "[]" indicate a provisional assignment based upon literature sources which were not verified by manufacturers data. The Person-in-Charge shall verify the cargo grade based on Manufacturers data and ensure that the barge is authorized for carriage of that grade of cargo.
A, B, C D, E Note 4	Flammable liquid cargoes, as defined in 46 CFR 30-10.22. Combustible liquid cargoes, as defined in 46 CFR 30-10.15. The flammability/combustibility grade of these cargoes may vary depending upon the flashpoint and Reid vapor pressure. The Person-in-Charge shall verify the cargo grade based on Manufacturers data and ensure that the barge is authorized for carriage of that grade of cargo.
NA #	Those subchapter O cargoes which are not classified as a flammable or combustible liquid. No flammability/combustibility grade has been assigned yet, as the necessary flash point/vapor pressure data for such assignments are presently not available.
Hull Type I II III NA	The required barge hull classification for carriage of the specified Subchapter O hazardous material cargo, see 46 CFR 151.10-1. Designed to carry products which require the maximum preventive measures to preclude the uncontrolled release of the cargo. See 46 CFR 151.10-1(b)(1). Designed to carry products which require significant preventive measures to preclude the uncontrolled release of cargo. See 46 CFR 151.10-1(b)(3). Designed to carry products of sufficient hazard to require a moderate degree of control. See 46 CFR 151.10-1(b)(4). Not applicable to barges certificated under Subchapter D.

Conditions of Carriage

Tank Group	The vessel's tank group (as defined in Section 4) which is authorized for carriage of the named cargo.
Vapor Recovery Approved (Y or N)	Yes: The vessel's VCS has been reviewed and approved by the MSC to control vapors of the specified cargo. No: The vessel's VCS has been reviewed and is not approved by the MSC to control vapors of the specified cargo.

Conditions of Carriage

Tank Group	The vessel's tank group (as defined under the "46 CFR Tank Group Characteristics" listed on page 1) which is authorized for carriage of the named cargo.
Vapor Recovery Approved (Y or N)	Yes: The vessel's VCS has been reviewed and approved by the MSC to control vapors of the specified cargo. No: The vessel's VCS has been reviewed and is not approved by the MSC to control vapors of the specified cargo.
VCS Category:	The specified cargo's provisional classification for vapor control systems.
Category 1	(No additional VCS requirements above those for benzene, gasoline and crude oil) All requirements applying to the handling of oil and hazardous materials in Titles 33 and 46 Code of Federal Regulations (CFR) apply to these cargoes. Those specifically dealing with vapor control systems are in 33 CFR 155.750, 33 CFR 156.120, 33 CFR 156.170, 46 CFR 35.35 and 46 CFR 39. The cargo tank venting system calculations (46 CFR 39.20-11) and the pressure drop calculations (46 CFR 39.30-1(b)) must use appropriate friction factors, vapor densities and vapor growth rates.
Category 2	(Polymerizes) Polymerization and residue build-up of these cargoes can adversely affect the vessel by fouling safety components and restricting vapor flow which could lead to cargo tank overpressurization. The vessel's owner must develop a method of ensuring all VCS safety components are functional and polymer build-up is not causing an unsafe condition due to increased pressure in the vapor control piping and cargo tanks. The method shall be acceptable to the local Officer in Charge, Marine Inspection. This is in addition to the requirements of Category 1. Please note that a material not normally considered a monomer can be a problem in detonation arrester.
Category 3	(Highly toxic) VCSs for these toxic cargoes cannot use a spill valve or rupture disk as the primary means to meet the overfill protection requirement of 46 CFR 39.20-9. This requirement is in addition to the requirements of Category 1.
Category 4	(Polymerizes and highly toxic) Must comply with requirements of Categories 1, 2 and 3.
Category 5	(High vapor pressure) VCS pressure drop calculations for cargoes with a vapor pressure greater than 14.7 psia at 115 F must take into account increased vapor-air mixture densities and vapor growth rates as compared to Category 1 cargoes. Consult the Marine Safety Center's VCS Guidelines for further information. This requirement is in addition to the requirements of Category 1.
Category 6	(High vapor pressure and highly toxic) Must comply with requirements of Categories 1, 3 and 5.
Category 7	(High vapor pressure and polymerizes) Must comply with requirements of Categories 1, 2 and 5.
none	The cargo has not been evaluated/classified for use in vapor control systems.



UNITED STATES OF AMERICA

DEPARTMENT OF HOMELAND SECURITY
UNITED STATES COAST GUARD

NATIONAL VESSEL DOCUMENTATION CENTER

CERTIFICATE OF DOCUMENTATION

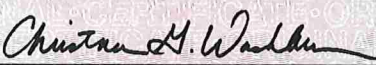
VESSEL NAME CCL 22		OFFICIAL NUMBER 1191600	IMO OR OTHER NUMBER 9541	YEAR COMPLETED 2007	
HAILING PORT BATON ROUGE LA		HULL MATERIAL STEEL		MECHANICAL PROPULSION NO	
GROSS TONNAGE 735 GRT	NET TONNAGE 735 NRT	LENGTH 200.0	BREADTH 35.0	DEPTH 12.5	
PLACE BUILT GALVESTON TX					
OWNERS CHEM CARRIERS LLC COMPRISED OF ONE MEMBER			OPERATIONAL ENDORSEMENTS COASTWISE		
MANAGING OWNER CHEM CARRIERS LLC 1237 HIGHWAY 75 SUNSHINE LA 70780					
RESTRICTIONS NONE					
ENTITLEMENTS NONE					
REMARKS NONE					
ISSUE DATE NOVEMBER 18, 2025		 DIRECTOR, NATIONAL VESSEL DOCUMENTATION CENTER			
THIS CERTIFICATE EXPIRES DECEMBER 31, 2026					

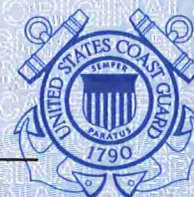

Certificate of Financial Responsibility (COFR)

<https://www.uscg.mil/Mariners/National-Pollution-Funds-Center/COFRs/ECOFR-Active-Vessel-Status/>

Updated: 04/10/2025 14:00

Vessel Name	Vin	Vessel Type Code	Vsl Vessel Type Desc	Gross Tonnage	Case Control Id	Case- Examiner Id	Case- Operator Name	Effective Date	Expiration Date	Insurance Cancel Flag
CCL 1	D518612	50	TANKBARGE	812	841310	22	CHEM CARRIERS, L.L.C	9/2/2022 12:00:00 AM	9/2/2025 12:00:00 AM	
CCL 2	D510107	50	TANKBARGE	855	841310	22	CHEM CARRIERS, L.L.C	6/23/2023 12:00:00 AM	6/23/2026 12:00:00 AM	
CCL 3	D296363	50	TANKBARGE	822	841310	22	CHEM CARRIERS, L.L.C	10/3/2023 12:00:00 AM	10/3/2026 12:00:00 AM	
CCL 4	D512519	50	TANKBARGE	860	841310	22	CHEM CARRIERS, L.L.C	4/7/2025 4:00:00 AM	4/7/2028 12:00:00 AM	
CCL 5	D512520	50	TANKBARGE	860	841310	22	CHEM CARRIERS, L.L.C	12/6/2022 12:00:00 AM	12/6/2025 12:00:00 AM	
CCL 6	D530996	50	TANKBARGE	798	841310	22	CHEM CARRIERS, L.L.C	1/26/2025 5:00:00 AM	1/26/2028 12:00:00 AM	
CCL 7	D551980	50	TANKBARGE	773	841310	22	CHEM CARRIERS, L.L.C	11/27/2023 12:00:00 AM	11/27/2026 12:00:00 AM	
CCL 8	D551982	50	TANKBARGE	773	841310	22	CHEM CARRIERS, L.L.C	9/27/2023 12:00:00 AM	9/27/2025 12:00:00 AM	
CCL 9	D551983	50	TANKBARGE	773	841310	22	CHEM CARRIERS, L.L.C	2/19/2023 12:00:00 AM	2/19/2026 12:00:00 AM	
CCL 10	D551979	50	TANKBARGE	773	841310	22	CHEM CARRIERS, L.L.C	12/12/2023 12:00:00 AM	12/12/2026 12:00:00 AM	
CCL 11	D551976	50	TANKBARGE	773	841310	22	CHEM CARRIERS, L.L.C	9/29/2022 12:00:00 AM	9/29/2025 12:00:00 AM	
CCL 14	D4497784	50	TANKBARGE	735	841310	22	CHEM CARRIERS, L.L.C	9/22/2022 12:00:00 AM	9/22/2025 12:00:00 AM	
CCL 15	D1164452	50	TANKBARGE	735	841310	22	CHEM CARRIERS, L.L.C	3/1/2024 12:00:00 AM	3/1/2027 12:00:00 AM	
CCL 16	D1164666	50	TANKBARGE	735	841310	22	CHEM CARRIERS, L.L.C	9/14/2024 12:00:00 AM	9/14/2027 12:00:00 AM	
CCL 17	D1166179	50	TANKBARGE	735	841310	22	CHEM CARRIERS, L.L.C	1/31/2023 12:00:00 AM	1/31/2026 12:00:00 AM	
CCL 18	D1168981	50	TANKBARGE	735	841310	22	CHEM CARRIERS, L.L.C	7/1/2023 12:00:00 AM	7/1/2026 12:00:00 AM	
CCL 19	D1168980	50	TANKBARGE	735	841310	22	CHEM CARRIERS, L.L.C	8/24/2023 12:00:00 AM	8/24/2026 12:00:00 AM	
CCL 20	D1191598	50	TANKBARGE	735	841310	22	CHEM CARRIERS, L.L.C	2/27/2025 5:00:00 AM	2/27/2028 12:00:00 AM	
CCL 21	D1191599	50	TANKBARGE	793	841310	22	CHEM CARRIERS, L.L.C	2/26/2025 5:00:00 AM	2/26/2028 12:00:00 AM	
CCL 22	D1191600	50	TANKBARGE	735	841310	22	CHEM CARRIERS, L.L.C	1/13/2025 5:00:00 AM	1/13/2028 12:00:00 AM	
CCL 23	D1191601	50	TANKBARGE	793	841310	22	CHEM CARRIERS, L.L.C	4/20/2025 4:00:00 AM	4/20/2028 12:00:00 AM	
CCL 24	D1196547	50	TANKBARGE	735	841310	22	CHEM CARRIERS, L.L.C	8/11/2023 12:00:00 AM	8/11/2026 12:00:00 AM	
CCL 25	D1196548	50	TANKBARGE	735	841310	22	CHEM CARRIERS, L.L.C	8/11/2023 12:00:00 AM	8/11/2026 12:00:00 AM	
CCL 26	D1203816	50	TANKBARGE	735	841310	22	CHEM CARRIERS, L.L.C	2/11/2025 5:00:00 AM	2/11/2028 12:00:00 AM	
CCL 27	D1203817	50	TANKBARGE	735	841310	22	CHEM CARRIERS, L.L.C	5/3/2024 12:00:00 AM	5/3/2027 12:00:00 AM	
CCL 28	D1212828	50	TANKBARGE	793	841310	22	CHEM CARRIERS, L.L.C	9/9/2023 12:00:00 AM	9/9/2026 12:00:00 AM	
CCL 29	D1212829	50	TANKBARGE	793	841310	22	CHEM CARRIERS, L.L.C	9/22/2023 12:00:00 AM	9/22/2026 12:00:00 AM	
CCL 30	D1305871	50	TANKBARGE	735	841310	22	CHEM CARRIERS, L.L.C	10/1/2023 12:00:00 AM	10/1/2026 12:00:00 AM	
CCL 31	D1305870	50	TANKBARGE	735	841310	22	CHEM CARRIERS, L.L.C	10/1/2023 12:00:00 AM	10/1/2026 12:00:00 AM	
CCL 32	D1305869	50	TANKBARGE	735	841310	22	CHEM CARRIERS, L.L.C	11/13/2023 12:00:00 AM	11/13/2026 12:00:00 AM	
CCL 33	D1305868	50	TANKBARGE	735	841310	22	CHEM CARRIERS, L.L.C	11/13/2023 12:00:00 AM	11/13/2026 12:00:00 AM	
CCL 401	D1216671	50	TANKBARGE	2001	841310	22	CHEM CARRIERS, L.L.C	4/13/2024 12:00:00 AM	4/13/2027 12:00:00 AM	
CCL 402	D1219910	50	TANKBARGE	1754	841310	22	CHEM CARRIERS, L.L.C	4/29/2024 12:00:00 AM	4/29/2027 12:00:00 AM	
CCL 403	D1231311	50	TANKBARGE	1691	841310	22	CHEM CARRIERS, L.L.C	2/8/2023 12:00:00 AM	2/8/2026 12:00:00 AM	
CCL 404	D1231312	50	TANKBARGE	1619	841310	22	CHEM CARRIERS, L.L.C	2/23/2026 12:00:00 AM	2/23/2026 12:00:00 AM	
CCL 405	D1236867	50	TANKBARGE	1619	841310	22	CHEM CARRIERS, L.L.C	1/1/2024 12:00:00 AM	1/1/2027 12:00:00 AM	
CCL 406	D1236866	50	TANKBARGE	1691	841310	22	CHEM CARRIERS, L.L.C	1/27/2024 12:00:00 AM	1/27/2027 12:00:00 AM	
CCL 407	D1246320	50	TANKBARGE	1754	841310	22	CHEM CARRIERS, L.L.C	8/22/2022 12:00:00 AM	8/22/2025 12:00:00 AM	
CCL 408	D1246097	50	TANKBARGE	1619	841310	22	CHEM CARRIERS, L.L.C	8/7/2022 12:00:00 AM	8/7/2025 12:00:00 AM	
CCL 409	D1246098	50	TANKBARGE	1619	841310	22	CHEM CARRIERS, L.L.C	10/2/2022 12:00:00 AM	10/2/2025 12:00:00 AM	
CCL 410	D1255906	50	TANKBARGE	1619	841310	22	CHEM CARRIERS, L.L.C	9/3/2023 12:00:00 AM	9/3/2026 12:00:00 AM	
CCL 411	D1255907	50	TANKBARGE	1619	841310	22	CHEM CARRIERS, L.L.C	9/25/2023 12:00:00 AM	9/25/2026 12:00:00 AM	
CCL 414-L	D1262941	50	TANKBARGE	1619	841310	22	CHEM CARRIERS, L.L.C	9/23/2024 4:00:00 AM	9/23/2027 12:00:00 AM	
CCL 415-T	D1262942	50	TANKBARGE	1619	841310	22	CHEM CARRIERS, L.L.C	9/28/2024 4:00:00 AM	9/28/2027 12:00:00 AM	
CCL 416-T	D1264691	50	TANKBARGE	1619	841310	22	CHEM CARRIERS, L.L.C	1/20/2025 5:00:00 AM	1/20/2028 12:00:00 AM	
CCL 417-T	D1298307	50	TANKBARGE	1769	841310	22	CHEM CARRIERS, L.L.C	1/27/2023 12:00:00 AM	1/27/2026 12:00:00 AM	
CCL 418-L	D1306896	50	TANKBARGE	1619	841310	22	CHEM CARRIERS, L.L.C	11/13/2023 12:00:00 AM	11/13/2026 12:00:00 AM	
CCL 419-L	D1306897	50	TANKBARGE	1619	841310	22	CHEM CARRIERS, L.L.C	1/5/2024 12:00:00 AM	1/5/2027 12:00:00 AM	
CCL 420-T	D1348560	50	TANKBARGE	1619	841310	22	CHEM CARRIERS, L.L.C	2/12/2025 5:00:00 AM	2/12/2028 12:00:00 AM	
AX 3202	D1089031	50	TANKBARGE	1754	841310	22	CHEM CARRIERS, L.L.C	6/11/2024 4:00:00 AM	6/11/2027 12:00:00 AM	
MERLIN BANTA	D249614	51	TUG AND TOWBOAT	384	841310	22	CHEM CARRIERS, L.L.C	11/24/2024 5:00:00 AM	11/24/2027 12:00:00 AM	



BARGE PIPING LETTER

INSTURCTIONS: ALL FIELDS ARE REQUIRED. USE N/A ON ANY NON-APPLICABLE LINE.

BARGE OWNER/BARGE NAME: Chem Carriers / CCL 22

Letter expiration date (one year from test date): 01-06-2027

NOTE: Test results are valid for (1) year from the date of test.

- 1. Cargo Piping and Valves (actual date of test): 01-06-2026
Test Pressure (188 psi): 188 Psi
- 2. Cargo Relief Valve (actual date of test): 01-06-2026
Test Pressure (125 psi): 125 Psi
- 3. Cargo Pressure Gauge (actual date of test): 01-06-2026
Percent of Accuracy (%): 98%
- 4. Steam Piping and Relief Valves (actual date of test): N/A
Test Pressure (125 psi): N/A

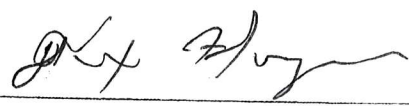
Signature of Tester:	
Printed Name of Tester:	FEUX HORIZAN
Company/Location of Tester:	Ksolv / Channelview Tx



BARGE VAPOR TIGHTNESS LETTER

NOTE: Test results are valid for (1) one year from date of test

- Test date: 01-06-2026
- Barge owner: Chem Carriers
- Barge Name/Official Number: CCL 22 / 1191600
- Maximum load rate (BPH): 3,500 (BPH)

→ Pressure cargo tanks and vapor system to (28) twenty-eight inches of water using a Manometer to record the time and pressure. Close all valves and allow the vessel to Remain pressure for (30) thirty minutes. Use soap to test and inspect for leaks. After (30) thirty minutes, record pressure and times.

→ Test cargo tanks and Vapor System to 28 inches of water.

→ Start Time: 20:00 Beginning Pressure: 28"

→ End Time: 20:30 Ending Pressure: 27.8"

✓ This vessel has been tested in accordance with Section 61.304f and has been found to to be vapor tight.

Company of Tester:	Location:
<u>K-solv Maritime</u>	<u>Channelview Tx</u>
Name of Tester (Print):	Signature of Tester:
<u>Felix Huizon</u>	
Name of Witness (Print):	Signature of Witness:
<u>Luis Lara</u>	
Affiliation/Company of Witness (Print)	
<u>Ksolv / Foreman</u>	

1015 Lakeside Dr, Channelview, TX 77530

Phone: 281-452-4000 Fax: 281-452-5523

Revised 10/03/2019

CCL 22

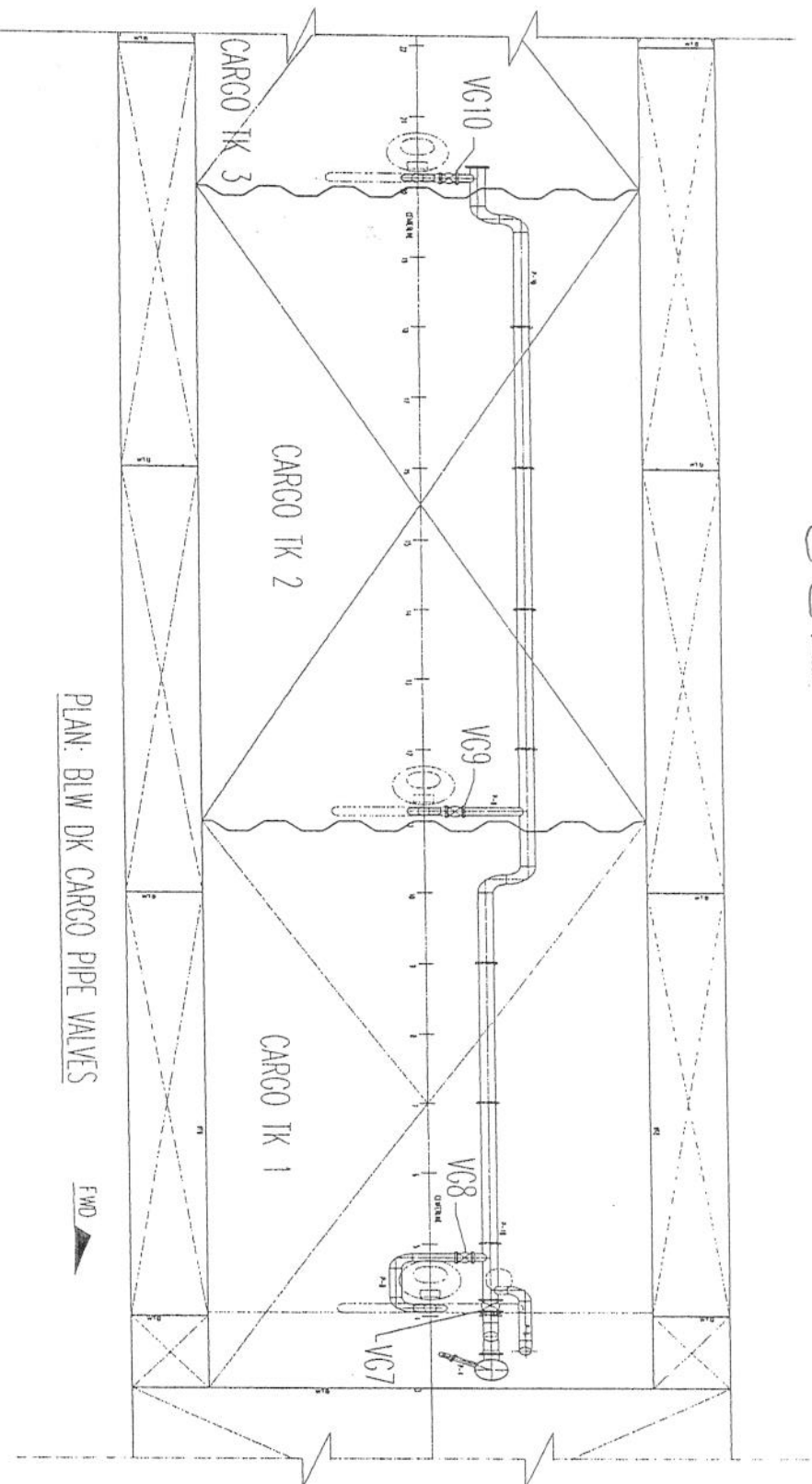

PLAN: BLW DK CARGO PIPE VALVES

FWD

- PLAN: ABV DK CARGO PIPE VALVES
- VALVE LEGEND
- VG1 = MAIN HEADER PORT DISCHARGE VALVE
 - VG2 = MAIN HEADER STBD DISCHARGE VALVE
 - VG3 = MAIN HEADER LOADING VALVE
 - VG4 = PUMP MASTER SUCTION VALVE
 - VC5 = PUMP CHECK VALVE

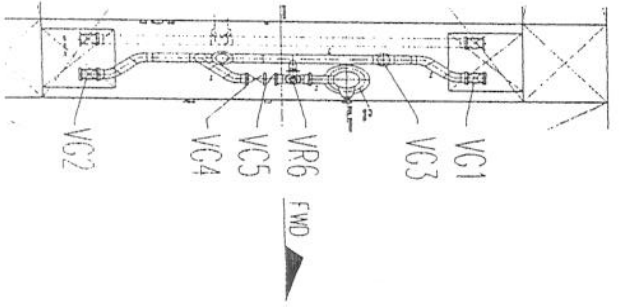

- VALVE LEGEND
- VG7 = PUMP DISCHARGE GATE VALVE
 - VG8 = CI 1 SUCTION VALVE
 - VG9 = CI 2 SUCTION VALVE
 - VG10 = CI 3 SUCTION VALVE

VDK = DRUM DEFLECT VALVE

CCL 22 Cargo & Vapor Piping

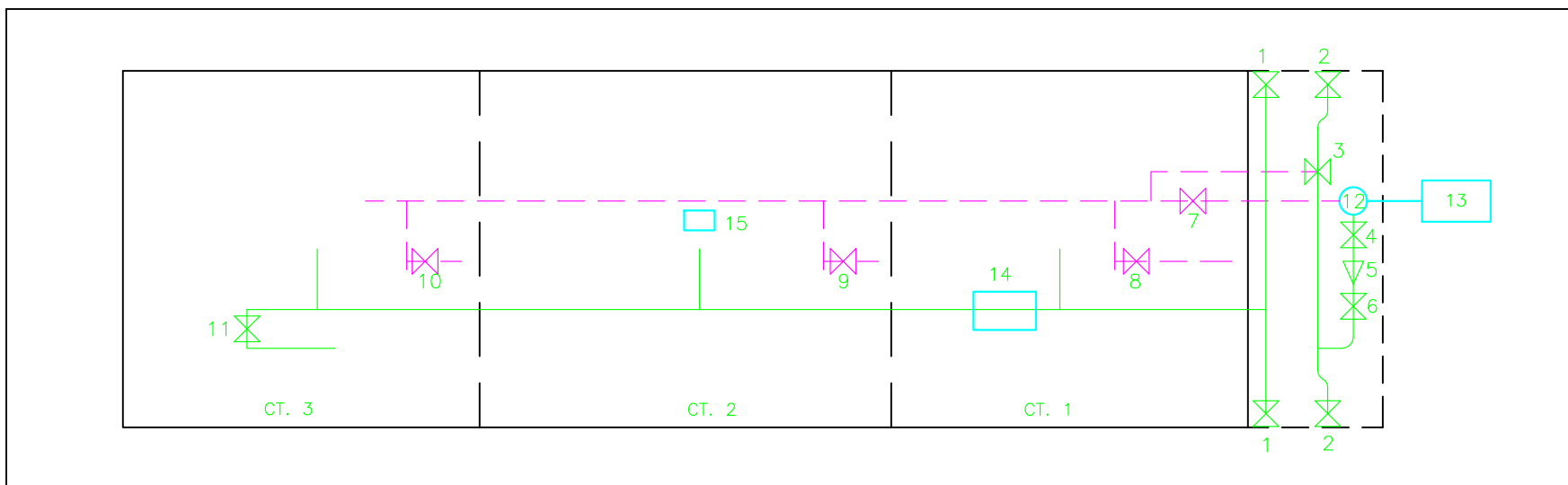

Parts List

ITEM	QTY	NAME	ITEM	QTY	NAME	ITEM	QTY	NAME
1	2	Vapor Header Valve	7	1	Master Suction Valve	13	1	Pump Engine
2	2	Cargo Header Valve	8	1	No. 1 Cargo Tank Valve	14	1	High Velocity PV Valve
3	1	Drop Valve / Load Valve	9	1	No. 2 Cargo Tank Valve	15	1	Emergency Shutdown
			10	1	No. 3 Cargo Tank Valve			
4	1	Pressure Release Valve	11	1	Vent Stack Valve			
5	1	Pump Discharge Check Valve	12	1	Deep Well Pump			
6	1	Pump Discharge Valve						

Edited 07/13/2020

CARGO TRANSFER PROCEDURES

CHEM CARRIERS L.L.C.

TRANSFER FROM BARGE TO DOCK

PARTS

1. PRODUCTS TRANSFERRED
2. DESCRIPTION OF SYSTEM
3. PERSONS ON DUTY
4. PERSONS IN CHARGE
5. EMERGENCY SHUTDOWN
6. TOPPING OFF PROCEDURE
7. COMPLETION OF TRANSFER
8. REPORTING CARGO SPILLS
9. VESSEL CLOSURES
10. PRODUCT DATA
11. Vapor Control Procedures
12. Inert system

Barge CCL 22

PARTS 1. PRODUCTS TRANSFERRED

33 CFR 155.750 (a) (1) (i)

This vessel is certificated for the carriage of grades "A" and lower Sub-Chapter (D) and (O) Products. It has also been certified to carry vapor products. Reference Certificate of Inspection.

PARTS 2. DESCRIPTION OF CARGO TRANSFER SYSTEM

33 CFR 155.750 (a) (2) (i) (ii)

The cargo transfer procedures apply to all Chem Carrier L.L.C. owned or leased tank barges. In most cases other than series built barges, the cargo piping arrangement is usually slightly different on every barge, and for this reason, the piping diagram must be studied before loading or discharging a barge. The basic concept for loading and discharging is fairly standard depending on the location of the pump.

A. (Reference the piping diagram for transfer system arrangement.)

B. PROCEDURES FOR THE CONTAINMENT SYSTEM

33 CFR 155.310 (a) (1) (iv)

33 CFR 155.750 (a) (2) (iii)

1). The containment pans are equipped with a drain for the removal of slops to shore facilities:

NEVER DRAIN THE CONTAINMENT TANKS ONTO THE DECK.

2). CCL 22 is equipped with a separate containment area for

the cargo trunk top and the forward deck area. Each containment area is equipped with drains and scupper plugs. Plugs should be installed prior to cargo transfer and removed after the cargo transfer is complete. PIC should notify Chem Carriers when containment areas need cleaning or if scupper plugs need replacing. **Never Drain Product captured in containment area overboard.**

PARTS 3. PERSONS ON DUTY DURING TRANSFER

33 CFR 155.750 (a) (3)

Number of persons required on duty during transfer operations:

- A. At no time during the transfer operation will be less than one responsible person on duty. The certified tankerman assigned shall be in charge and responsible for the safe transfer of cargo.

PARTS 4. PERSONS IN CHARGE

The tanker man (person in charge) is responsible for transferring cargo and carrying out related operations on board in an efficient, safe, and pollution free manner. The tankerman whether employed by the towboat, owner, operator, a shore tankerman service, or Chem Carriers L.L.C., shall comply with all Coast Guard, State and local regulations. Tankerman's responsibility shall include but not be limited to the following:

- A. To have on his/her person a valid merchant marine document endorsed as tankerman, certified to handle the grade of cargo to be transferred.
- B. Make a thorough inspection of the barge prior to the start of transfer operation.
- C. To have proper connection of the grounding cable.
- D. The vessel's moorings are adequate to hold during all expected conditions of surge, current, wind, tide, ect., and lines are long enough to allow for surge, tide, wind, changes in draft ect.
- E. Proper hose sizes, lengths, support, and connections.
- F. The condition of fire extinguishers and required number.
- G. The person in charge of transfer operations on the transferring vessel or facility and the person in charge of transferring operations on the receiving vessel or facility agree to begin the transfer operations.
- H. The transfer operation between tank barges and dock facilities should be lighted between sunset and sunrise to comply with the U. S. Coast Guard regulation pertaining to the displaying of lights on barges as required by Title 33.
- I. The PIC (PERSON IN CHARGE) will be responsible for the DOI (declaration of inspection) and DOS (declaration of security).
- J. Always maintain communications with dock or shore personnel with an agreed upon approved system.

PARTS 5: EMERGENCY SHUTDOWN

33 CFR 155.750 (a) (6)

THE EMERGENCY SHUTDOWN IS LOCATED NEAR THE CENTER OF THE BARGE.

- A. In the event of an emergency, transfer operations can be stopped by pulling the remote shutdown cable.
- B. Familiarize yourself with its location and operation prior to transfer.

PARTS 6; TOPPING OFF PROCEDURES

33 CFR 155.750 (a) (7)

In the process of topping off, tanks should be loaded at different levels to top off one at a time. Extra care should be taken to avoid over pressuring the connections, and hoses by closing valves against the receiving line. Since barges and facilities vary in their systems, no standard for topping off exist, but the following should be considered:

- A. The closing of one tank increases the rate of flow to other tanks on the same line.
- B. Always consider temperature and cargo in accordance with the amount of expansion that should be allowed.
- C. Always maintain communications with dock or shore personnel.
- D. A set of dipstick overfill devices have been installed on the CCL 22. Dipsticks can be made operational by releasing the covers or caps. Dipsticks should be used as a visual aid for overfill protection.

PARTS 7: COMPLETION OF TRANSFER

33 CFR 155.750 (a) (8)

Upon the completion of the transfer all pipelines should be drained into cargo tanks. The header valve used during the operation should than be closed, sealed off with a blind flange and shore personnel should seal lines and hatches on vessel.

PARTS 8: REPORTING CARGO SPILLS

33 CFR 155.750 (a) (9)

Should an accidental discharge of product occur, you should consider the following:

- A. Locate the source of the spill and try to stop it, if possible, and safe to do so.

- B. Make an attempt to contain the product if possible.
- C. Notify the Coast Guard. The national Response Center at 1-800-424-9300.
- D. Notify Chem Carriers L.L.C. at (225) 642-0060 or Digital pager# 800-213-4791.
- E. If loading, transfer the cargo from the leaking tank to an adjacent tank or back to the dock if safe to do so.
- E. If discharging, pump the product from the leaking tank as quickly as possible if safe to do so.

***When reporting a spill, the tankerman should provide the following information:**

- A. Name (his or her)
- B. Name of Company: (employed by; (contracted by;
- C. Name of Barge.
- D. Spill Location
- E. Specify Product.
- F. Estimate Quantity of Spill
- G. Weather, Tide, Sea and Current Conditions.
- H. Cause of Spill.
- I. Action Being Taken to Contain and Stop Spill

PART 9

CLOSURES ON VESSELS

Upon completion of cargo transfer operations, all tank hatch covers, ullage covers, and gauging device covers shall be dogged down and secured. In addition, the vent drain valves, if installed, should be secured and left in the proper position. All drain valves should be closed, and drip pan covers, if installed, should be made up tight. Covers for void spaces, bow and stern compartments shall be secured at all times and checked for tightness. Closing devices on clean-out hatches and clean-out opening should be checked, especially when the barge is loaded.

PART 10

PRODUCT DATA

See specific MSDS sheets provided with these procedures.

Incase of any other emergency, immediately shut down and notify the transferring facility, and Chem Carriers L.L.C. (225) 642-0060 24 Hour Line.

PART 11

VAPOR CONTROL PROCEDURES

This is a guide only and is not intended to replace experience, sound judgment, and a proper assessment of the task at hand.

The tankerman on duty is the acting Designated Person In Charge (PIC) and is responsible for cargo transfer operations and carrying out related operations on barges.

1. Vapor Recovery Transfer Maximum Rate is 2300 BBLs/HR for subchapter "D" Cargoes and 2400 BBBLs/Hr for subchapter "O" Cargoes.
- 1.1 Transfer rates, which exceed these maximums, must be approved by Chem Carriers.
- 1.2 Transfer rates for each cargo tank should not exceed the maximum transfer rate.

2. Pre-transfer Inspection For Vapor Recovery Operations

2.1 Follow the procedures outlined below in addition to the procedures utilized during normal transfers:

2.1.1 Wear personal protective equipment (PPE) as needed for the cargo in the barge when testing P/V and, hooking up hoses, or draining low points.

2.1.2 Ensure that a Certificate of Vapor Tightness is onboard and valid.

2.1.3 Close the low point drain on the port/starboard vapor header, if applicable.

2.1.4 Close the low point drain near the vent stack, if applicable.

2.1.5 Close valve to the vent riser if applicable.

2.1.7 Blinds used for the vapor control manifold should have a hole to accommodate the 1/2" stud located in the vapor header.

2.1.8 Each cargo tank is fitted with a liquid level gauge stick. Remove the cap, raise the stick, This stick can be monitored visually to avoid overfilling.

2.1.9 Ensure that the last one meter (3.3 feet) of vapor piping before the vapor connection is painted red/yellow/red.

2.1.10 The cross-header should be stenciled with the word "VAPOR" in black letters at least 2" high.

2.1.11 The vapor connection flange should be fixed with a 1" long by 1/2" diameter stud projecting outward from the face of the flange, midway between bolt holes.

2.1.12 The high level alarms/shutdowns are installed near the center of each cargo tank. Dock alarm/shutdown should be connected prior to loading, and plugs located near the forward end of the barge Port and Starboard should be labeled "ALARM/SHUTDOWN SENSOR." High level alarms are set to alarm at 90% of the cargo tanks capacity and Shut downs are set to shut transfer down at 95% of each tanks capacity.

2.1.13 Ensure that the P/V relief valve flame screen, if required, is in place and in good condition prior to testing.

2.1.14 Ensure that the facility has a Letter of Adequacy endorsed as meeting the requirements of 33 CFR Subpart E.

3. Vapor Piping

3.1 The PIC checks the vapor piping diagram.

3.2 Characteristics of a vapor header:

3.2.1 The vapor collection piping system on tank barges is permanently installed and located as close as practical to the loading manifold. The piping system is electrically bonded to the hull and electrically continuous.

3.2.2 The last one meter (3.3 feet) of vapor piping prior to the valve before the vapor connection is painted red/yellow/red. The red bands are 4" wide and the yellow band is 32" wide.

3.2.3 The vapor header is stenciled with the word "VAPOR" in black letters at least 2" high.

3.2.4 The vapor connection flange is to be fixed with a 1" by 1/2" diameter stud projecting outward from the face of the flange. This stud is located at the top of the flange, midway between bolt holes.

3.2.5 When not in use, blank off the vapor headers using a blind flange with a bolt in every hole. Each blind flange used on the vapor piping has a hole drilled to accommodate the pin.

4. Inspection And Verification Of Vent Lines

4.1 The Person in Charge performs the following steps:

4.1.1 Checks the Certificate of Inspection on board the barge;

4.1.2 Locates polymerizing or inhibited cargoes in the section of the COI marked *Specific Hazardous Cargo Authority*;

4.1.3 Refers to the MSDS or Chemical Data Guide on board the vessel to determine what cargoes are subject to polymerization, or what cargoes are inhibited;

4.1.4 Locates the MSDS for the cargo and determines its toxicity and whether or not it is a polymerizing or inhibited cargo; and,

4.1.5 Notifies the Dispatcher and Field Supervisor when polymerization is suspected.

5. Any problems with the Vapor Control system must be reported immediately to the person in charge and Chem Carriers.

Part 12: Inert System

1. CCL 22 is equipped with a closed nitrogen) system that will maintain 3 pounds of pressure and/or 3 pounds of vacuum specifically used to transport EDC (Ethylene dichloride). CCL 22 is equipped with pressure gauges on the vapor line. These gauges should be visually monitored during cargo transfer to maintain a proper transfer rate. The Pressure Vacuum Vent Valve is set to relieve pressure/Vacuum at 3 pounds at maximum flow rate.
2. Prior to load or discharge: the dock nitrogen system should be connected and opened in order to maintain a positive pressure to the cargo tank system while loading or discharging. When the pressure on the barge reaches (3# max pressure) the dock nitrogen should be turned off and disconnected.
3. Note: stack butterfly valve has been blanked off while inert system is in use.
4. CCL 22 is equipped with hermetic gauging devices located near the center of each cargo tank these gauging devices are used for closed gauging purposes.

U.S. Department of
Homeland Security

United States
Coast Guard



Commandant
United States Coast Guard

2703 Martin Luther King Jr. Ave SE
Stop 7516
Washington, DC 20593-7516
Staff Symbol: CG-MER-4 (VRP)
Phone: (202) 372-1005
Fax: (202) 372-8376
Email: vrp@uscg.mil

16460
March 12, 2025

Chem Carriers, L.L.C.
C/O: FOREFRONT EMERGENCY MANAGEMENT, LP
ATTN: ALLIE MARTIN
1730 COTEAU ROAD
HOUMA, LA 70364

Dear Sir or Madam:

Your Vessel Response Plan (Control Number 56041), submitted to meet the requirements of Title 33, Code of Federal Regulations (CFR), Part 155, Subparts D and I, is **approved**. Approval will remain valid until **March 21, 2030**.

The CCL 22 (1191600) is authorized to operate only in the ports or geographic areas indicated in the Captain of the Port zones listed below. If carrying oil as cargo, the vessel is prohibited from handling, storing, transporting, transferring, or lightering oil unless it is operating in full compliance with this plan. Compliance includes ensuring that required resources have been identified and planned for or are in place and available through contract or other approved means. If applicable to your routes, this includes the dispersant and aerial observation requirements of 33 CFR 155.1050.

You are reminded that your chosen salvage and marine firefighting resource provider may have submitted waivers from meeting one or more of the specified response times in accordance with 33 CFR 155.4055. If so, this may be rescinded by the U.S. Coast Guard if the appropriate response resources are not available when the approved waiver expires. You shall continue to assess the adequacy of your chosen salvors and firefighters as required by 33 CFR 155.4050.

The vessel must keep a copy of this approval letter onboard in addition to the minimum sections of the plan as required by 33 CFR 155.1030. In accordance with 33 CFR 155.1070, you are required to review your plan annually and submit plan amendments for approval. As per 33 CFR 155.1070(b), the entire plan must be resubmitted for a comprehensive review and approval six (6) months prior to the expiration date.

APPROVED CAPTAIN OF THE PORT ZONES

CORPUS CHRISTI
HOUMA
HOUSTON-GALVESTON

LOWER MISSISSIPPI RIVER OHIO VALLEY
(MEMPHIS) PORT ARTHUR AND LAKE
MOBILE CHARLES
NEW ORLEANS

UPPER MISSISSIPPI RIVER
(ST. LOUIS)

Sincerely,



CHARRON MCCOMBS

Lieutenant Commander

Acting Chief, Domestic Preparedness & Planning Division

U.S. Coast Guard

By direction

U.S. Department of
Homeland Security

United States
Coast Guard



Commanding Officer
United States Coast Guard
Marine Safety Center

US Coast Guard Stop 7430
2703 Martin Luther King Jr. Ave. SE
Washington, DC 20593-7430
Staff Symbol: MSC-5
Phone: (202) 795-6729
Email: securityplaninfo@uscg.mil

16710
VS-326893
December 3, 2024

Chem Carriers, LLC
Attn: Robert Banta
1237 Hwy 75
Sunshine, LA 70780
robert@chemcarriers.com

Subj: CHEM CARRIERS, LLC VESSELS
VESSEL SECURITY PLAN APPROVAL WITH AMENDMENTS

Ref: (a) Your correspondence dated November 6, 2024
(b) Title 33 Code of Federal Regulations (CFR) Part 104
(c) MSC Vessel Security Plan Approval letter dated October 16, 2024

Dear Mr. Banta:

We have conducted a review of the Vessel Security Plan (VSP) submitted with reference (a) in accordance with reference (b) and it is **“Approved.”**

Your vessel must operate in compliance with this approved VSP and the requirements contained in reference (b). You are reminded to immediately report any deviation from this approved plan to the local Captain of the Port (COTP)/Officer in Charge, Marine Inspection (OCMI).

This approval will remain valid until five years from the date of reference (c) unless rescinded in writing by the local COTP/OCMI. You must review your plan annually and submit any amendments to this office for approval. Please ensure that a copy of the VSP is maintained on board the vessel if manned, or, if unmanned, at a suitable secure location so that it is readily available during an emergency or security incident. You shall make available to the Coast Guard, upon request, this letter, the VSP and any information related to the implementation of the VSP. Our Case Number for this plan is 326893. Please ensure that all future correspondence includes this Case Number.

Sincerely,

K. C. WILLIAMS
Lieutenant Commander, U.S. Coast Guard
Chief, Vessel Security Division
By direction

Enclosures: (1) List of Vessel Security Plan Amendments
(2) List of Vessels Covered

List of Vessels Covered

<u>Vessel Name</u>	<u>Official Number (O.N.)</u>
CCL-1	518612
CCL 2	510107
CCL-3	296363
CCL 4	512519
CCL-5	512520
CCL-6	530996
CCL7	551980
CCL 8	551982
CCL 9	551983
CCL 10	551979
CCL 11	551976
CCL 14	1164451
CCL 15	1164452
CCL 16	1164666
CCL 17	1166179
CCL 18	1168981
CCL 19	1168980
CCL 20	1191598
CCL 21	1191599
CCL 22	1191600
CCL 23	1191601
CCL 24	1196547
CCL 25	1196548
CCL 26	1203816
CCL 27	1203817
CCL 28	1212828
CCL 29	1212829
CCL 30	1305871
CCL 31	1305870
CCL 32	1305869
CCL 33	1305868
CCL 401	1216671
CCL 402	1219910
CCL 403	1231311
CCL 404	1231312
CCL 405	1236867
CCL 406	1236866
CCL 407	1246320
CCL 408	1246097
CCL 409	1246098
CCL 410	1255906
CCL 411	1255907
CCL 414-L	1262941
CCL 415-T	1262942

<u>Vessel Name</u>	<u>Official Number (O.N.)</u>
CCL 416-T	1264691
CCL 417 T	1298307
CCL 418-L	1306896
CCL 419-L	1306897
CCL 420-T	1348560
CCL 421-T	CG1843359
CCL 3202	1089031
HFL 413	1237482
HFL 415	1237483
HFL 435	1236563
HFL 605	1237484



BARGE "UCL 22"

1 CENTER INNAGE TABLE

CAPACITIES GIVEN IN WHOLE GALLONS

GAUGE HEIGHT 16'-01 1/2"

IN	0 FT.	IN	1 FT.	IN	2 FT.	IN	3 FT.	IN	4 FT.	IN	5 FT.	IN	6 FT.	IN	7 FT.	IN	8 FT.	IN	9 FT.
0	22	0	9,847	0	19,905	0	29,997	0	40,198	0	50,399	0	60,599	0	70,795	0	80,994	0	91,199
1/4	201	1/4	10,060	1/4	20,111	1/4	30,210	1/4	40,410	1/4	50,611	1/4	60,812	1/4	71,008	1/4	81,207	1/4	91,412
1/2	380	1/2	10,273	1/2	20,317	1/2	30,422	1/2	40,623	1/2	50,824	1/2	61,024	1/2	71,220	1/2	81,419	1/2	91,625
3/4	559	3/4	10,486	3/4	20,522	3/4	30,635	3/4	40,835	3/4	51,036	3/4	61,237	3/4	71,432	3/4	81,632	3/4	91,837
1	738	1	10,700	1	20,728	1	30,847	1	41,048	1	51,249	1	61,449	1	71,644	1	81,844	1	92,050
1/4	925	1/4	10,913	1/4	20,934	1/4	31,060	1/4	41,260	1/4	51,461	1/4	61,662	1/4	71,857	1/4	82,057	1/4	92,263
1/2	1,112	1/2	11,126	1/2	21,139	1/2	31,272	1/2	41,473	1/2	51,674	1/2	61,874	1/2	72,069	1/2	82,270	1/2	92,475
3/4	1,299	3/4	11,339	3/4	21,345	3/4	31,485	3/4	41,685	3/4	51,886	3/4	62,087	3/4	72,281	3/4	82,482	3/4	92,688
2	1,487	2	11,552	2	21,551	2	31,697	2	41,898	2	52,099	2	62,299	2	72,493	2	82,695	2	92,900
1/4	1,680	1/4	11,765	1/4	21,757	1/4	31,910	1/4	42,110	1/4	52,311	1/4	62,512	1/4	72,706	1/4	82,908	1/4	93,113
1/2	1,874	1/2	11,978	1/2	21,962	1/2	32,122	1/2	42,323	1/2	52,524	1/2	62,724	1/2	72,918	1/2	83,120	1/2	93,325
3/4	2,068	3/4	12,191	3/4	22,168	3/4	32,335	3/4	42,535	3/4	52,736	3/4	62,937	3/4	73,130	3/4	83,333	3/4	93,538
3	2,262	3	12,404	3	22,374	3	32,547	3	42,748	3	52,949	3	63,149	3	73,343	3	83,545	3	93,750
1/4	2,463	1/4	12,618	1/4	22,579	1/4	32,760	1/4	42,960	1/4	53,161	1/4	63,362	1/4	73,555	1/4	83,758	1/4	93,962
1/2	2,663	1/2	12,831	1/2	22,785	1/2	32,972	1/2	43,173	1/2	53,374	1/2	63,574	1/2	73,767	1/2	83,971	1/2	94,175
3/4	2,863	3/4	13,044	3/4	22,991	3/4	33,185	3/4	43,386	3/4	53,586	3/4	63,787	3/4	73,979	3/4	84,183	3/4	94,387
4	3,064	4	13,257	4	23,197	4	33,397	4	43,598	4	53,799	4	63,999	4	74,192	4	84,396	4	94,600
1/4	3,270	1/4	13,470	1/4	23,409	1/4	33,610	1/4	43,811	1/4	54,011	1/4	64,212	1/4	74,404	1/4	84,608	1/4	94,812
1/2	3,476	1/2	13,683	1/2	23,622	1/2	33,822	1/2	44,023	1/2	54,224	1/2	64,425	1/2	74,616	1/2	84,821	1/2	95,025
3/4	3,683	3/4	13,896	3/4	23,834	3/4	34,035	3/4	44,236	3/4	54,436	3/4	64,625	3/4	74,829	3/4	85,034	3/4	95,237
5	3,889	5	14,109	5	24,047	5	34,247	5	44,448	5	54,649	5	64,850	5	75,041	5	85,246	5	95,449
1/4	4,100	1/4	14,323	1/4	24,259	1/4	34,460	1/4	44,661	1/4	54,861	1/4	65,062	1/4	75,253	1/4	85,459	1/4	95,662
1/2	4,312	1/2	14,536	1/2	24,472	1/2	34,672	1/2	44,873	1/2	55,074	1/2	65,275	1/2	75,466	1/2	85,671	1/2	95,874
3/4	4,523	3/4	14,749	3/4	24,684	3/4	34,885	3/4	45,086	3/4	55,286	3/4	65,487	3/4	75,679	3/4	85,884	3/4	96,087
6	4,735	6	14,962	6	24,897	6	35,097	6	45,298	6	55,499	6	65,700	6	75,891	6	86,097	6	96,299
1/4	4,948	1/4	15,168	1/4	25,109	1/4	35,310	1/4	45,511	1/4	55,711	1/4	65,912	1/4	76,104	1/4	86,309	1/4	96,512
1/2	5,160	1/2	15,375	1/2	25,322	1/2	35,522	1/2	45,723	1/2	55,924	1/2	66,125	1/2	76,316	1/2	86,522	1/2	96,724
3/4	5,373	3/4	15,581	3/4	25,534	3/4	35,735	3/4	45,936	3/4	56,136	3/4	66,337	3/4	76,529	3/4	86,735	3/4	96,936
7	5,585	7	15,788	7	25,747	7	35,947	7	46,148	7	56,349	7	66,550	7	76,742	7	86,947	7	97,149
1/4	5,798	1/4	15,994	1/4	25,959	1/4	36,160	1/4	46,361	1/4	56,561	1/4	66,762	1/4	76,954	1/4	87,160	1/4	97,361
1/2	6,011	1/2	16,201	1/2	26,172	1/2	36,373	1/2	46,573	1/2	56,774	1/2	66,974	1/2	77,167	1/2	87,372	1/2	97,574
3/4	6,224	3/4	16,407	3/4	26,384	3/4	36,585	3/4	46,786	3/4	56,986	3/4	67,187	3/4	77,380	3/4	87,585	3/4	97,786
8	6,437	8	16,614	8	26,597	8	36,798	8	46,998	8	57,199	8	67,399	8	77,592	8	87,798	8	97,999
1/4	6,650	1/4	16,819	1/4	26,809	1/4	37,010	1/4	47,211	1/4	57,412	1/4	67,611	1/4	77,805	1/4	88,010	1/4	98,211
1/2	6,863	1/2	17,025	1/2	27,022	1/2	37,223	1/2	47,423	1/2	57,624	1/2	67,823	1/2	78,017	1/2	88,223	1/2	98,424
3/4	7,076	3/4	17,231	3/4	27,234	3/4	37,435	3/4	47,636	3/4	57,837	3/4	68,036	3/4	78,230	3/4	88,435	3/4	98,636
9	7,290	9	17,437	9	27,447	9	37,648	9	47,848	9	58,049	9	68,248	9	78,443	9	88,648	9	98,849
1/4	7,503	1/4	17,642	1/4	27,659	1/4	37,860	1/4	48,061	1/4	58,262	1/4	68,460	1/4	78,655	1/4	88,861	1/4	99,062
1/2	7,716	1/2	17,848	1/2	27,872	1/2	38,073	1/2	48,273	1/2	58,474	1/2	68,672	1/2	78,868	1/2	89,073	1/2	99,274
3/4	7,929	3/4	18,054	3/4	28,084	3/4	38,285	3/4	48,486	3/4	58,687	3/4	68,885	3/4	79,080	3/4	89,286	3/4	99,487
10	8,142	10	18,259	10	28,297	10	38,498	10	48,698	10	58,899	10	69,097	10	79,293	10	89,499	10	99,699
1/4	8,355	1/4	18,465	1/4	28,509	1/4	38,710	1/4	48,911	1/4	59,112	1/4	69,309	1/4	79,506	1/4	89,711	1/4	99,912
1/2	8,568	1/2	18,671	1/2	28,722	1/2	38,923	1/2	49,123	1/2	59,324	1/2	69,522	1/2	79,718	1/2	89,924	1/2	100,125
3/4	8,781	3/4	18,877	3/4	28,934	3/4	39,135	3/4	49,336	3/4	59,537	3/4	69,734	3/4	79,931	3/4	90,136	3/4	100,337
11	8,995	11	19,082	11	29,147	11	39,348	11	49,548	11	59,749	11	69,946	11	80,144	11	90,349	11	100,550
1/4	9,208	1/4	19,288	1/4	29,360	1/4	39,560	1/4	49,761	1/4	59,962	1/4	70,158	1/4	80,356	1/4	90,562	1/4	100,763
1/2	9,421	1/2	19,494	1/2	29,572	1/2	39,773	1/2	49,973	1/2	60,174	1/2	70,371	1/2	80,569	1/2	90,774	1/2	100,975
3/4	9,634	3/4	19,699	3/4	29,785	3/4	39,985	3/4	50,186	3/4	60,387	3/4	70,583	3/4	80,781	3/4	90,987	3/4	101,188

CERTIFIED CHART FOR THE ABOVE NAMED TANK ONLY.

BARGE STRAPPED AND COMPUTED IN ACCORDANCE WITH MPMS CHAPTER 2.7.

CAPACITY TABLE ONLY APPLIES WHEN BARGE IS ON EVEN KEEL.

CAPACITY TABLE EXTENDS TO EXTREME HEIGHT OF TANK.

CAPACITY TABLE ONLY APPLIES TO INNAGE GAUGES TAKEN TO THREADS ON "MMC" VALVE.

GAUGE POINT: (MMC) LOCATED ON CENTERLINE AND 27'-03" FORWARD OF AFT BULKHEAD.

PRECISION MEASUREMENT
& ANALYSIS, INC.

P. O. Box 2092
Pearland, Texas 77588
<http://www.pmacorp.net>



BARGE "UCL 22"

1 CENTER INNAGE TABLE

CAPACITIES GIVEN IN WHOLE GALLONS

GAUGE HEIGHT 16'-01 1/2"

IN	10 FT.	IN	11 FT.	IN	12 FT.	IN	13 FT.	IN	14 FT.	IN	15 FT.	IN	16 FT.	IN	17 FT.	IN	18 FT.	IN	19 FT.
0	101,400	0	110,939	0	119,820	0	128,701	0	137,582	0	146,351	0	0	0	0	0	0	0	0
1/4	101,613	1/4	111,124	1/4	120,005	1/4	128,886	1/4	137,767	1/4	146,436	1/4							1/4
1/2	101,826	1/2	111,309	1/2	120,190	1/2	129,071	1/2	137,952	1/2	146,521	1/2							1/2
3/4	102,038	3/4	111,494	3/4	120,375	3/4	129,256	3/4	138,137	3/4	146,606	3/4							3/4
1	102,251	1	111,679	1	120,560	1	129,442	1	138,322	1	146,691	1							1
1/4	102,463	1/4	111,864	1/4	120,745	1/4	129,627	1/4	138,507	1/4	146,734	1/4							1/4
1/2	102,676	1/2	112,049	1/2	120,930	1/2	129,812	1/2	138,692	1/2	146,777	1/2							1/2
3/4	102,889	3/4	112,234	3/4	121,115	3/4	129,997	3/4	138,877	3/4	146,819	3/4							3/4
2	103,101	2	112,419	2	121,300	2	130,182	2	139,062	2	146,862	2							2
1/4	103,314	1/4	112,604	1/4	121,486	1/4	130,367	1/4	139,247	1/4	146,872	1/4							1/4
1/2	103,527	1/2	112,789	1/2	121,671	1/2	130,552	1/2	139,432	1/2	146,883	1/2							1/2
3/4	103,739	3/4	112,974	3/4	121,856	3/4	130,737	3/4	139,617	3/4		3/4							3/4
3	103,952	3	113,159	3	122,041	3	130,922	3	139,802	3		3							3
1/4	104,164	1/4	113,345	1/4	122,226	1/4	131,107	1/4	139,987	1/4		1/4							1/4
1/2	104,377	1/2	113,530	1/2	122,411	1/2	131,292	1/2	140,172	1/2		1/2							1/2
3/4	104,590	3/4	113,715	3/4	122,596	3/4	131,477	3/4	140,357	3/4		3/4							3/4
4	104,802	4	113,900	4	122,781	4	131,662	4	140,542	4		4							4
1/4	105,015	1/4	114,085	1/4	122,966	1/4	131,847	1/4	140,727	1/4		1/4							1/4
1/2	105,227	1/2	114,270	1/2	123,151	1/2	132,032	1/2	140,912	1/2		1/2							1/2
3/4	105,440	3/4	114,455	3/4	123,336	3/4	132,217	3/4	141,097	3/4		3/4							3/4
5	105,653	5	114,640	5	123,521	5	132,402	5	141,282	5		5							5
1/4	105,865	1/4	114,825	1/4	123,706	1/4	132,587	1/4	141,467	1/4		1/4							1/4
1/2	106,078	1/2	115,010	1/2	123,891	1/2	132,772	1/2	141,652	1/2		1/2							1/2
3/4	106,291	3/4	115,195	3/4	124,076	3/4	132,957	3/4	141,837	3/4		3/4							3/4
6	106,503	6	115,380	6	124,261	6	133,142	6	142,022	6		6							6
1/4	106,688	1/4	115,565	1/4	124,446	1/4	133,327	1/4	142,207	1/4		1/4							1/4
1/2	106,872	1/2	115,750	1/2	124,631	1/2	133,512	1/2	142,392	1/2		1/2							1/2
3/4	107,057	3/4	115,935	3/4	124,816	3/4	133,697	3/4	142,577	3/4		3/4							3/4
7	107,241	7	116,120	7	125,001	7	133,882	7	142,762	7		7							7
1/4	107,425	1/4	116,305	1/4	125,186	1/4	134,067	1/4	142,947	1/4		1/4							1/4
1/2	107,610	1/2	116,490	1/2	125,371	1/2	134,252	1/2	143,132	1/2		1/2							1/2
3/4	107,794	3/4	116,675	3/4	125,556	3/4	134,437	3/4	143,317	3/4		3/4							3/4
8	107,979	8	116,860	8	125,741	8	134,622	8	143,502	8		8							8
1/4	108,164	1/4	117,045	1/4	125,926	1/4	134,807	1/4	143,708	1/4		1/4							1/4
1/2	108,349	1/2	117,230	1/2	126,111	1/2	134,992	1/2	143,914	1/2		1/2							1/2
3/4	108,534	3/4	117,415	3/4	126,296	3/4	135,177	3/4	144,120	3/4		3/4							3/4
9	108,719	9	117,600	9	126,481	9	135,362	9	144,326	9		9							9
1/4	108,904	1/4	117,785	1/4	126,666	1/4	135,547	1/4	144,534	1/4		1/4							1/4
1/2	109,089	1/2	117,970	1/2	126,851	1/2	135,732	1/2	144,742	1/2		1/2							1/2
3/4	109,274	3/4	118,155	3/4	127,036	3/4	135,917	3/4	144,949	3/4		3/4							3/4
10	109,459	10	118,340	10	127,221	10	136,102	10	145,157	10		10							10
1/4	109,644	1/4	118,525	1/4	127,406	1/4	136,287	1/4	145,328	1/4		1/4							1/4
1/2	109,829	1/2	118,710	1/2	127,591	1/2	136,472	1/2	145,498	1/2		1/2							1/2
3/4	110,014	3/4	118,895	3/4	127,776	3/4	136,657	3/4	145,669	3/4		3/4							3/4
11	110,199	11	119,080	11	127,961	11	136,842	11	145,839	11		11							11
1/4	110,384	1/4	119,265	1/4	128,146	1/4	137,027	1/4	145,967	1/4		1/4							1/4
1/2	110,569	1/2	119,450	1/2	128,331	1/2	137,212	1/2	146,095	1/2		1/2							1/2
3/4	110,754	3/4	119,635	3/4	128,516	3/4	137,397	3/4	146,223	3/4		3/4							3/4

STRAPPED: 02/08/2007 CL - SW
CALCULATED: 02/08/2007 CL
PRINTED: 02/08/2007 CL

CANCELS AND SUPERCEDES
ALL PRIOR TO 02/2007

CERTIFIED CHART FOR THE ABOVE NAMED TANK ONLY.

PRECISION MEASUREMENT
& ANALYSIS, INC.
P.O. Box 2092
Pearland, Texas 77568
<http://www.pmacorp.net>



BARGE "CCL 22"

2 CENTER INNAGE TABLE

CAPACITIES GIVEN IN WHOLE GALLONS

GAUGE HEIGHT 16'-02"

IN	0 FT.	IN	1 FT.	IN	2 FT.	IN	3 FT.	IN	4 FT.	IN	5 FT.	IN	6 FT.	IN	7 FT.	IN	8 FT.	IN	9 FT.
0	22	0	11,520	0	22,945	0	34,431	0	46,040	0	57,648	0	69,257	0	80,866	0	92,475	0	104,083
1/4	254	1/4	11,762	1/4	23,180	1/4	34,673	1/4	46,281	1/4	57,890	1/4	69,499	1/4	81,108	1/4	92,716	1/4	104,325
1/2	486	1/2	12,003	1/2	23,414	1/2	34,915	1/2	46,523	1/2	58,132	1/2	69,741	1/2	81,350	1/2	92,958	1/2	104,567
3/4	718	3/4	12,245	3/4	23,648	3/4	35,156	3/4	46,765	3/4	58,374	3/4	69,983	3/4	81,591	3/4	93,200	3/4	104,809
1	950	1	12,487	1	23,882	1	35,398	1	47,007	1	58,616	1	70,224	1	81,833	1	93,442	1	105,051
1/4	1,186	1/4	12,729	1/4	24,116	1/4	35,640	1/4	47,249	1/4	58,858	1/4	70,466	1/4	82,075	1/4	93,684	1/4	105,293
1/2	1,422	1/2	12,971	1/2	24,350	1/2	35,882	1/2	47,491	1/2	59,099	1/2	70,708	1/2	82,317	1/2	93,926	1/2	105,534
3/4	1,657	3/4	13,212	3/4	24,584	3/4	36,124	3/4	47,733	3/4	59,341	3/4	70,950	3/4	82,559	3/4	94,168	3/4	105,776
2	1,893	2	13,454	2	24,819	2	36,366	2	47,974	2	59,583	2	71,192	2	82,801	2	94,409	2	106,018
1/4	2,130	1/4	13,696	1/4	25,053	1/4	36,608	1/4	48,216	1/4	59,825	1/4	71,434	1/4	83,042	1/4	94,651	1/4	106,260
1/2	2,368	1/2	13,938	1/2	25,287	1/2	36,849	1/2	48,458	1/2	60,067	1/2	71,676	1/2	83,284	1/2	94,893	1/2	106,502
3/4	2,605	3/4	14,180	3/4	25,521	3/4	37,091	3/4	48,700	3/4	60,309	3/4	71,917	3/4	83,526	3/4	95,135	3/4	106,744
3	2,842	3	14,421	3	25,755	3	37,333	3	48,942	3	60,551	3	72,159	3	83,768	3	95,377	3	106,985
1/4	3,081	1/4	14,663	1/4	25,989	1/4	37,575	1/4	49,184	1/4	60,792	1/4	72,401	1/4	84,010	1/4	95,619	1/4	107,227
1/2	3,320	1/2	14,905	1/2	26,223	1/2	37,817	1/2	49,426	1/2	61,034	1/2	72,643	1/2	84,252	1/2	95,860	1/2	107,469
3/4	3,559	3/4	15,147	3/4	26,458	3/4	38,059	3/4	49,667	3/4	61,276	3/4	72,885	3/4	84,494	3/4	96,102	3/4	107,711
4	3,798	4	15,388	4	26,692	4	38,300	4	49,909	4	61,518	4	73,127	4	84,735	4	96,344	4	107,953
1/4	4,038	1/4	15,630	1/4	26,934	1/4	38,542	1/4	50,151	1/4	61,760	1/4	73,369	1/4	84,977	1/4	96,586	1/4	108,195
1/2	4,278	1/2	15,872	1/2	27,175	1/2	38,784	1/2	50,393	1/2	62,002	1/2	73,610	1/2	85,219	1/2	96,828	1/2	108,437
3/4	4,518	3/4	16,114	3/4	27,417	3/4	39,026	3/4	50,635	3/4	62,243	3/4	73,852	3/4	85,461	3/4	97,070	3/4	108,678
5	4,757	5	16,356	5	27,659	5	39,268	5	50,877	5	62,485	5	74,094	5	85,703	5	97,312	5	108,920
1/4	4,998	1/4	16,597	1/4	27,901	1/4	39,510	1/4	51,118	1/4	62,727	1/4	74,336	1/4	85,945	1/4	97,553	1/4	109,162
1/2	5,239	1/2	16,839	1/2	28,143	1/2	39,752	1/2	51,360	1/2	62,969	1/2	74,578	1/2	86,187	1/2	97,795	1/2	109,404
3/4	5,479	3/4	17,081	3/4	28,385	3/4	39,993	3/4	51,602	3/4	63,211	3/4	74,820	3/4	86,428	3/4	98,037	3/4	109,646
6	5,720	6	17,323	6	28,627	6	40,235	6	51,844	6	63,453	6	75,061	6	86,670	6	98,279	6	109,888
1/4	5,961	1/4	17,565	1/4	28,868	1/4	40,477	1/4	52,086	1/4	63,695	1/4	75,303	1/4	86,912	1/4	98,521	1/4	110,130
1/2	6,203	1/2	17,792	1/2	29,110	1/2	40,719	1/2	52,328	1/2	63,936	1/2	75,545	1/2	87,154	1/2	98,763	1/2	110,371
3/4	6,444	3/4	18,026	3/4	29,352	3/4	40,961	3/4	52,570	3/4	64,178	3/4	75,787	3/4	87,396	3/4	99,004	3/4	110,613
7	6,685	7	18,261	7	29,594	7	41,203	7	52,811	7	64,420	7	76,029	7	87,638	7	99,246	7	110,855
1/4	6,927	1/4	18,495	1/4	29,836	1/4	41,445	1/4	53,053	1/4	64,662	1/4	76,271	1/4	87,879	1/4	99,488	1/4	111,097
1/2	7,168	1/2	18,730	1/2	30,078	1/2	41,686	1/2	53,295	1/2	64,904	1/2	76,513	1/2	88,121	1/2	99,730	1/2	111,339
3/4	7,410	3/4	18,964	3/4	30,319	3/4	41,928	3/4	53,537	3/4	65,146	3/4	76,754	3/4	88,363	3/4	99,972	3/4	111,581
8	7,651	8	19,199	8	30,561	8	42,170	8	53,779	8	65,388	8	76,996	8	88,605	8	100,214	8	111,822
1/4	7,893	1/4	19,433	1/4	30,803	1/4	42,412	1/4	54,021	1/4	65,629	1/4	77,238	1/4	88,847	1/4	100,456	1/4	112,064
1/2	8,135	1/2	19,667	1/2	31,045	1/2	42,654	1/2	54,262	1/2	65,871	1/2	77,480	1/2	89,089	1/2	100,697	1/2	112,306
3/4	8,377	3/4	19,901	3/4	31,287	3/4	42,896	3/4	54,504	3/4	66,113	3/4	77,722	3/4	89,331	3/4	100,939	3/4	112,548
9	8,618	9	20,136	9	31,529	9	43,137	9	54,746	9	66,355	9	77,964	9	89,572	9	101,181	9	112,790
1/4	8,860	1/4	20,370	1/4	31,771	1/4	43,379	1/4	54,988	1/4	66,597	1/4	78,206	1/4	89,814	1/4	101,423	1/4	113,032
1/2	9,102	1/2	20,604	1/2	32,012	1/2	43,621	1/2	55,230	1/2	66,839	1/2	78,447	1/2	90,056	1/2	101,665	1/2	113,274
3/4	9,344	3/4	20,838	3/4	32,254	3/4	43,863	3/4	55,472	3/4	67,080	3/4	78,689	3/4	90,298	3/4	101,907	3/4	113,515
10	9,586	10	21,072	10	32,496	10	44,105	10	55,714	10	67,322	10	78,931	10	90,540	10	102,149	10	113,757
1/4	9,827	1/4	21,306	1/4	32,738	1/4	44,347	1/4	55,955	1/4	67,564	1/4	79,173	1/4	90,782	1/4	102,390	1/4	113,999
1/2	10,069	1/2	21,540	1/2	32,980	1/2	44,589	1/2	56,197	1/2	67,806	1/2	79,415	1/2	91,023	1/2	102,632	1/2	114,241
3/4	10,311	3/4	21,775	3/4	33,222	3/4	44,830	3/4	56,439	3/4	68,048	3/4	79,657	3/4	91,265	3/4	102,874	3/4	114,483
11	10,553	11	22,009	11	33,463	11	45,072	11	56,681	11	68,290	11	79,898	11	91,507	11	103,116	11	114,725
1/4	10,795	1/4	22,243	1/4	33,705	1/4	45,314	1/4	56,923	1/4	68,532	1/4	80,140	1/4	91,749	1/4	103,358	1/4	114,967
1/2	11,036	1/2	22,477	1/2	33,947	1/2	45,556	1/2	57,165	1/2	68,773	1/2	80,382	1/2	91,991	1/2	103,600	1/2	115,208
3/4	11,278	3/4	22,711	3/4	34,189	3/4	45,798	3/4	57,407	3/4	69,015	3/4	80,624	3/4	92,233	3/4	103,841	3/4	115,450

BARGE STRAPPED AND COMPUTED IN ACCORDANCE WITH MPMS CHAPTER 2.7.
 CAPACITY TABLE ONLY APPLIES WHEN BARGE IS ON EVEN KEEL.
 CAPACITY TABLE EXTENDS TO EXTREME HEIGHT OF TANK.
 CAPACITY TABLE ONLY APPLIES TO INNAGE GAUGES TAKEN TO THREADS ON "MMC" VALVE.
 GAUGE POINT: (MMC) LOCATED ON CENTERLINE AND 27'-00" FORWARD OF AFT BULKHEAD.

CERTIFIED CHART FOR THE ABOVE NAMED TANK ONLY.

PRECISION MEASUREMENT
 & ANALYSIS, INC.
 P.O. Box 2092
 Pearland, Texas 77588
<http://www.pmacorp.net>



BARGE "CCL 22"

2 CENTER INNAGE TABLE

CAPACITIES GIVEN IN WHOLE GALLONS

GAUGE HEIGHT 16'-02"

IN	10 FT.	IN	11 FT.	IN	12 FT.	IN	13 FT.	IN	14 FT.	IN	15 FT.	IN	16 FT.	IN	17 FT.	IN	18 FT.	IN	19 FT.
0	115,692	0	127,301	0	138,910	0	150,518	0	162,126	0	173,732	0		0					
1/4	115,934	1/4	127,543	1/4	139,151	1/4	150,760	1/4	162,368	1/4	173,225	1/4							
1/2	116,176	1/2	127,784	1/2	139,393	1/2	151,002	1/2	162,610	1/2	173,321	1/2							
3/4	116,418	3/4	128,026	3/4	139,635	3/4	151,244	3/4	162,852	3/4	173,418	3/4							
1	116,659	1	128,268	1	139,877	1	151,486	1	163,093	1	173,515	1							
1/4	116,901	1/4	128,510	1/4	140,119	1/4	151,728	1/4	163,335	1/4	173,563	1/4							
1/2	117,143	1/2	128,752	1/2	140,361	1/2	151,969	1/2	163,577	1/2	173,611	1/2							
3/4	117,385	3/4	128,994	3/4	140,602	3/4	152,211	3/4	163,819	3/4	173,659	3/4							
2	117,627	2	129,236	2	140,844	2	152,453	2	164,061	2	173,708	2							
1/4	117,869	1/4	129,477	1/4	141,086	1/4	152,695	1/4	164,303	1/4	173,720	1/4							
1/2	118,111	1/2	129,719	1/2	141,328	1/2	152,937	1/2	164,544	1/2	173,732	1/2							
3/4	118,352	3/4	129,961	3/4	141,570	3/4	153,179	3/4	164,786	3/4		3/4							
3	118,594	3	130,203	3	141,812	3	153,420	3	165,028	3		3							
1/4	118,836	1/4	130,445	1/4	142,054	1/4	153,662	1/4	165,270	1/4		1/4							
1/2	119,078	1/2	130,687	1/2	142,295	1/2	153,904	1/2	165,512	1/2		1/2							
3/4	119,320	3/4	130,929	3/4	142,537	3/4	154,146	3/4	165,753	3/4		3/4							
4	119,562	4	131,170	4	142,779	4	154,388	4	165,995	4		4							
1/4	119,803	1/4	131,412	1/4	143,021	1/4	154,630	1/4	166,237	1/4		1/4							
1/2	120,045	1/2	131,654	1/2	143,263	1/2	154,872	1/2	166,479	1/2		1/2							
3/4	120,287	3/4	131,896	3/4	143,505	3/4	155,113	3/4	166,721	3/4		3/4							
5	120,529	5	132,138	5	143,747	5	155,355	5	166,962	5		5							
1/4	120,771	1/4	132,380	1/4	143,988	1/4	155,597	1/4	167,204	1/4		1/4							
1/2	121,013	1/2	132,621	1/2	144,230	1/2	155,839	1/2	167,446	1/2		1/2							
3/4	121,255	3/4	132,863	3/4	144,472	3/4	156,081	3/4	167,688	3/4		3/4							
6	121,496	6	133,105	6	144,714	6	156,323	6	167,930	6		6							
1/4	121,738	1/4	133,347	1/4	144,956	1/4	156,564	1/4	168,171	1/4		1/4							
1/2	121,980	1/2	133,589	1/2	145,198	1/2	156,806	1/2	168,413	1/2		1/2							
3/4	122,222	3/4	133,831	3/4	145,439	3/4	157,048	3/4	168,655	3/4		3/4							
7	122,464	7	134,073	7	145,681	7	157,290	7	168,897	7		7							
1/4	122,706	1/4	134,314	1/4	145,923	1/4	157,532	1/4	169,139	1/4		1/4							
1/2	122,948	1/2	134,556	1/2	146,165	1/2	157,774	1/2	169,380	1/2		1/2							
3/4	123,189	3/4	134,798	3/4	146,407	3/4	158,016	3/4	169,622	3/4		3/4							
8	123,431	8	135,040	8	146,649	8	158,257	8	169,864	8		8							
1/4	123,673	1/4	135,282	1/4	146,891	1/4	158,499	1/4	170,106	1/4		1/4							
1/2	123,915	1/2	135,524	1/2	147,132	1/2	158,741	1/2	170,348	1/2		1/2							
3/4	124,157	3/4	135,765	3/4	147,374	3/4	158,983	3/4	170,589	3/4		3/4							
9	124,399	9	136,007	9	147,616	9	159,225	9	170,831	9		9							
1/4	124,640	1/4	136,249	1/4	147,858	1/4	159,466	1/4	171,067	1/4		1/4							
1/2	124,882	1/2	136,491	1/2	148,100	1/2	159,708	1/2	171,303	1/2		1/2							
3/4	125,124	3/4	136,733	3/4	148,342	3/4	159,950	3/4	171,538	3/4		3/4							
10	125,366	10	136,975	10	148,583	10	160,192	10	171,774	10		10							
1/4	125,608	1/4	137,217	1/4	148,825	1/4	160,434	1/4	171,968	1/4		1/4							
1/2	125,850	1/2	137,458	1/2	149,067	1/2	160,675	1/2	172,161	1/2		1/2							
3/4	126,092	3/4	137,700	3/4	149,309	3/4	160,917	3/4	172,354	3/4		3/4							
11	126,333	11	137,942	11	149,551	11	161,159	11	172,548	11		11							
1/4	126,575	1/4	138,184	1/4	149,793	1/4	161,401	1/4	172,693	1/4		1/4							
1/2	126,817	1/2	138,426	1/2	150,035	1/2	161,643	1/2	172,838	1/2		1/2							
3/4	127,059	3/4	138,668	3/4	150,276	3/4	161,884	3/4	172,983	3/4		3/4							

CERTIFIED CHART FOR THE ABOVE NAMED TANK ONLY.

STRAPPED: 02/08/2007 CL - SW
CALCULATED: 02/08/2007 CL
PRINTED: 02/08/2007 CL

CANCELS AND SUPERCEDES
ALL PRIOR TO 02/2007

PRECISION MEASUREMENT
& ANALYSIS, INC.
P.O. Box 2092
Pearland, Texas 77588
<http://www.pmacorp.net>



BARGE 'UCL 22"

3 CENTER INNAGE TABLE

CAPACITIES GIVEN IN WHOLE GALLONS

GAUGE HEIGHT 16'-01 1/4"

IN	0 FT.	IN	1 FT.	IN	2 FT.	IN	3 FT.	IN	4 FT.	IN	5 FT.	IN	6 FT.	IN	7 FT.	IN	8 FT.	IN	9 FT.
0	22	0	10,330	0	20,733	0	31,137	0	41,544	0	51,952	0	62,359	0	72,767	0	83,175	0	93,582
1/4	230	1/4	10,547	1/4	20,949	1/4	31,354	1/4	41,761	1/4	52,169	1/4	62,576	1/4	72,984	1/4	83,391	1/4	93,799
1/2	438	1/2	10,764	1/2	21,166	1/2	31,570	1/2	41,978	1/2	52,386	1/2	62,793	1/2	73,201	1/2	83,608	1/2	94,016
3/4	646	3/4	10,980	3/4	21,382	3/4	31,787	3/4	42,195	3/4	52,602	3/4	63,010	3/4	73,417	3/4	83,825	3/4	94,233
1	854	1	11,197	1	21,599	1	32,004	1	42,412	1	52,819	1	63,227	1	73,634	1	84,042	1	94,449
1 1/4	1,065	1 1/4	11,414	1 1/4	21,816	1 1/4	32,221	1 1/4	42,628	1 1/4	53,036	1 1/4	63,444	1 1/4	73,851	1 1/4	84,259	1 1/4	94,666
1 1/2	1,277	1 1/2	11,631	1 1/2	22,032	1 1/2	32,438	1 1/2	42,845	1 1/2	53,253	1 1/2	63,660	1 1/2	74,068	1 1/2	84,475	1 1/2	94,883
3/4	1,488	3/4	11,847	3/4	22,249	3/4	32,655	3/4	43,062	3/4	53,470	3/4	63,877	3/4	74,285	3/4	84,692	3/4	95,100
2	1,699	2	12,064	2	22,465	2	32,871	2	43,279	2	53,686	2	64,094	2	74,502	2	84,909	2	95,317
1 1/4	1,912	1 1/4	12,281	1 1/4	22,682	1 1/4	33,088	1 1/4	43,496	1 1/4	53,903	1 1/4	64,311	1 1/4	74,718	1 1/4	85,126	1 1/4	95,533
1 1/2	2,125	1 1/2	12,498	1 1/2	22,899	1 1/2	33,305	1 1/2	43,713	1 1/2	54,120	1 1/2	64,528	1 1/2	74,935	1 1/2	85,343	1 1/2	95,750
3/4	2,338	3/4	12,715	3/4	23,115	3/4	33,522	3/4	43,929	3/4	54,337	3/4	64,744	3/4	75,152	3/4	85,560	3/4	95,967
3	2,551	3	12,931	3	23,332	3	33,739	3	44,146	3	54,554	3	64,961	3	75,369	3	85,776	3	96,184
1 1/4	2,765	1 1/4	13,148	1 1/4	23,549	1 1/4	33,955	1 1/4	44,363	1 1/4	54,771	1 1/4	65,178	1 1/4	75,586	1 1/4	85,993	1 1/4	96,401
1 1/2	2,979	1 1/2	13,365	1 1/2	23,765	1 1/2	34,172	1 1/2	44,580	1 1/2	54,987	1 1/2	65,395	1 1/2	75,802	1 1/2	86,210	1 1/2	96,618
3/4	3,193	3/4	13,582	3/4	23,982	3/4	34,389	3/4	44,797	3/4	55,204	3/4	65,612	3/4	76,019	3/4	86,427	3/4	96,834
4	3,407	4	13,798	4	24,198	4	34,606	4	45,013	4	55,421	4	65,829	4	76,236	4	86,644	4	97,051
1 1/4	3,622	1 1/4	14,015	1 1/4	24,415	1 1/4	34,823	1 1/4	45,230	1 1/4	55,638	1 1/4	66,045	1 1/4	76,453	1 1/4	86,861	1 1/4	97,268
1 1/2	3,837	1 1/2	14,232	1 1/2	24,632	1 1/2	35,040	1 1/2	45,447	1 1/2	55,855	1 1/2	66,262	1 1/2	76,670	1 1/2	87,077	1 1/2	97,485
3/4	4,052	3/4	14,449	3/4	24,849	3/4	35,256	3/4	45,664	3/4	56,072	3/4	66,479	3/4	76,887	3/4	87,294	3/4	97,702
5	4,267	5	14,665	5	25,066	5	35,473	5	45,881	5	56,288	5	66,696	5	77,103	5	87,511	5	97,919
1 1/4	4,483	1 1/4	14,882	1 1/4	25,283	1 1/4	35,690	1 1/4	46,098	1 1/4	56,505	1 1/4	66,913	1 1/4	77,320	1 1/4	87,728	1 1/4	98,135
1 1/2	4,699	1 1/2	15,099	1 1/2	25,499	1 1/2	35,907	1 1/2	46,314	1 1/2	56,722	1 1/2	67,130	1 1/2	77,537	1 1/2	87,945	1 1/2	98,352
3/4	4,915	3/4	15,316	3/4	25,716	3/4	36,124	3/4	46,531	3/4	56,939	3/4	67,346	3/4	77,754	3/4	88,161	3/4	98,569
6	5,130	6	15,533	6	25,933	6	36,341	6	46,748	6	57,156	6	67,563	6	77,971	6	88,378	6	98,786
1 1/4	5,347	1 1/4	15,749	1 1/4	26,150	1 1/4	36,557	1 1/4	46,965	1 1/4	57,372	1 1/4	67,780	1 1/4	78,188	1 1/4	88,595	1 1/4	99,003
1 1/2	5,563	1 1/2	15,966	1 1/2	26,367	1 1/2	36,774	1 1/2	47,182	1 1/2	57,589	1 1/2	67,997	1 1/2	78,404	1 1/2	88,812	1 1/2	99,219
3/4	5,779	3/4	16,183	3/4	26,583	3/4	36,991	3/4	47,399	3/4	57,806	3/4	68,214	3/4	78,621	3/4	89,029	3/4	99,436
7	5,996	7	16,400	7	26,800	7	37,208	7	47,615	7	58,023	7	68,430	7	78,838	7	89,246	7	99,653
1 1/4	6,212	1 1/4	16,616	1 1/4	27,017	1 1/4	37,425	1 1/4	47,832	1 1/4	58,240	1 1/4	68,647	1 1/4	79,055	1 1/4	89,462	1 1/4	99,870
1 1/2	6,429	1 1/2	16,833	1 1/2	27,234	1 1/2	37,641	1 1/2	48,049	1 1/2	58,457	1 1/2	68,864	1 1/2	79,272	1 1/2	89,679	1 1/2	100,087
3/4	6,645	3/4	17,050	3/4	27,451	3/4	37,858	3/4	48,266	3/4	58,673	3/4	69,081	3/4	79,488	3/4	89,896	3/4	100,304
8	6,862	8	17,267	8	27,668	8	38,075	8	48,483	8	58,890	8	69,298	8	79,705	8	90,113	8	100,520
1 1/4	7,079	1 1/4	17,483	1 1/4	27,884	1 1/4	38,292	1 1/4	48,700	1 1/4	59,107	1 1/4	69,515	1 1/4	79,922	1 1/4	90,330	1 1/4	100,737
1 1/2	7,295	1 1/2	17,700	1 1/2	28,101	1 1/2	38,509	1 1/2	48,916	1 1/2	59,324	1 1/2	69,731	1 1/2	80,139	1 1/2	90,547	1 1/2	100,954
3/4	7,512	3/4	17,916	3/4	28,318	3/4	38,726	3/4	49,133	3/4	59,541	3/4	69,948	3/4	80,356	3/4	90,763	3/4	101,171
9	7,729	9	18,133	9	28,535	9	38,942	9	49,350	9	59,758	9	70,165	9	80,573	9	90,980	9	101,388
1 1/4	7,946	1 1/4	18,350	1 1/4	28,752	1 1/4	39,159	1 1/4	49,567	1 1/4	59,974	1 1/4	70,382	1 1/4	80,789	1 1/4	91,197	1 1/4	101,605
1 1/2	8,162	1 1/2	18,566	1 1/2	28,969	1 1/2	39,376	1 1/2	49,784	1 1/2	60,191	1 1/2	70,599	1 1/2	81,006	1 1/2	91,414	1 1/2	101,821
3/4	8,379	3/4	18,783	3/4	29,185	3/4	39,593	3/4	50,000	3/4	60,408	3/4	70,816	3/4	81,223	3/4	91,631	3/4	102,038
10	8,596	10	19,000	10	29,402	10	39,810	10	50,217	10	60,625	10	71,032	10	81,440	10	91,847	10	102,255
1 1/4	8,813	1 1/4	19,216	1 1/4	29,619	1 1/4	40,027	1 1/4	50,434	1 1/4	60,842	1 1/4	71,249	1 1/4	81,657	1 1/4	92,064	1 1/4	102,472
1 1/2	9,029	1 1/2	19,433	1 1/2	29,836	1 1/2	40,243	1 1/2	50,651	1 1/2	61,058	1 1/2	71,466	1 1/2	81,874	1 1/2	92,281	1 1/2	102,689
3/4	9,246	3/4	19,649	3/4	30,053	3/4	40,460	3/4	50,868	3/4	61,275	3/4	71,683	3/4	82,090	3/4	92,498	3/4	102,905
11	9,463	11	19,866	11	30,269	11	40,677	11	51,085	11	61,492	11	71,900	11	82,307	11	92,715	11	103,122
1 1/4	9,680	1 1/4	20,083	1 1/4	30,486	1 1/4	40,894	1 1/4	51,301	1 1/4	61,709	1 1/4	72,116	1 1/4	82,524	1 1/4	92,932	1 1/4	103,339
1 1/2	9,897	1 1/2	20,299	1 1/2	30,703	1 1/2	41,111	1 1/2	51,518	1 1/2	61,926	1 1/2	72,333	1 1/2	82,741	1 1/2	93,148	1 1/2	103,556
3/4	10,113	3/4	20,516	3/4	30,920	3/4	41,327	3/4	51,735	3/4	62,143	3/4	72,550	3/4	82,958	3/4	93,365	3/4	103,773

CERTIFIED CHART FOR THE ABOVE NAMED TANK ONLY.

BARGE STRAPPED AND COMPUTED IN ACCORDANCE WITH MPMS CHAPTER 2.7.
 CAPACITY TABLE ONLY APPLIES WHEN BARGE IS ON EVEN KEEL.
 CAPACITY TABLE EXTENDS TO EXTREME HEIGHT OF TANK.
 CAPACITY TABLE ONLY APPLIES TO INNAGE GAUGES TAKEN TO THREADS ON "MMC" VALVE.
 GAUGE POINT: (MMC) LOCATED ON CENTERLINE AND 27'-06" FORWARD OF AFT BULKHEAD.

PRECISION MEASUREMENT
& ANALYSIS, INC.
 P.O. Box 2092
 Pearland, Texas 77588
<http://www.pmacorp.net>



BARGE 'UCL 22"

3 CENTER INNAGE TABLE

GAUGE HEIGHT 16'-01 1/4"

CAPACITIES GIVEN IN WHOLE GALLONS

10 FT.		11 FT.		12 FT.		13 FT.		14 FT.		15 FT.		16 FT.		17 FT.		18 FT.		19 FT.	
IN	IN	IN	IN	IN	IN	IN	IN	IN	IN	IN	IN	IN	IN	IN	IN	IN	IN	IN	IN
0	103,990	0	114,397	0	124,805	0	135,212	0	145,619	0	155,483	0	0	0	0	0	0	0	0
1/4	104,206	1/4	114,614	1/4	125,022	1/4	135,429	1/4	145,836	1/4	155,569	1/4	1/4	1/4	1/4	1/4	1/4	1/4	1/4
1/2	104,423	1/2	114,831	1/2	125,238	1/2	135,646	1/2	146,053	1/2	155,656	1/2	1/2	1/2	1/2	1/2	1/2	1/2	1/2
3/4	104,640	3/4	115,048	3/4	125,455	3/4	135,863	3/4	146,270	3/4	155,743	3/4	3/4	3/4	3/4	3/4	3/4	3/4	3/4
1	104,857	1	115,264	1	125,672	1	136,080	1	146,486	1	155,829	1	1	1	1	1	1	1	1
1/4	105,074	1/4	115,481	1/4	125,889	1/4	136,296	1/4	146,703	1/4	155,872	1/4	1/4	1/4	1/4	1/4	1/4	1/4	1/4
1/2	105,291	1/2	115,698	1/2	126,106	1/2	136,513	1/2	146,920	1/2	155,916	1/2	1/2	1/2	1/2	1/2	1/2	1/2	1/2
3/4	105,507	3/4	115,915	3/4	126,322	3/4	136,730	3/4	147,137	3/4	155,959	3/4	3/4	3/4	3/4	3/4	3/4	3/4	3/4
2	105,724	2	116,132	2	126,539	2	136,947	2	147,353	2	156,002	2	2	2	2	2	2	2	2
1/4	105,941	1/4	116,349	1/4	126,756	1/4	137,164	1/4	147,570	1/4	156,014	1/4	1/4	1/4	1/4	1/4	1/4	1/4	1/4
1/2	106,158	1/2	116,565	1/2	126,973	1/2	137,380	1/2	147,787	1/2	156,013	1/2	1/2	1/2	1/2	1/2	1/2	1/2	1/2
3/4	106,375	3/4	116,782	3/4	127,190	3/4	137,597	3/4	148,004	3/4	156,013	3/4	3/4	3/4	3/4	3/4	3/4	3/4	3/4
3	106,591	3	116,999	3	127,407	3	137,814	3	148,221	3	156,013	3	3	3	3	3	3	3	3
1/4	106,808	1/4	117,216	1/4	127,623	1/4	138,031	1/4	148,437	1/4	156,013	1/4	1/4	1/4	1/4	1/4	1/4	1/4	1/4
1/2	107,025	1/2	117,433	1/2	127,840	1/2	138,248	1/2	148,654	1/2	156,013	1/2	1/2	1/2	1/2	1/2	1/2	1/2	1/2
3/4	107,242	3/4	117,650	3/4	128,057	3/4	138,465	3/4	148,871	3/4	156,013	3/4	3/4	3/4	3/4	3/4	3/4	3/4	3/4
4	107,459	4	117,866	4	128,274	4	138,681	4	149,088	4	156,013	4	4	4	4	4	4	4	4
1/4	107,676	1/4	118,083	1/4	128,491	1/4	138,898	1/4	149,304	1/4	156,013	1/4	1/4	1/4	1/4	1/4	1/4	1/4	1/4
1/2	107,892	1/2	118,300	1/2	128,708	1/2	139,115	1/2	149,521	1/2	156,013	1/2	1/2	1/2	1/2	1/2	1/2	1/2	1/2
3/4	108,109	3/4	118,517	3/4	128,924	3/4	139,332	3/4	149,738	3/4	156,013	3/4	3/4	3/4	3/4	3/4	3/4	3/4	3/4
5	108,326	5	118,734	5	129,141	5	139,549	5	149,955	5	156,013	5	5	5	5	5	5	5	5
1/4	108,543	1/4	118,950	1/4	129,358	1/4	139,766	1/4	150,172	1/4	156,013	1/4	1/4	1/4	1/4	1/4	1/4	1/4	1/4
1/2	108,760	1/2	119,167	1/2	129,575	1/2	139,982	1/2	150,388	1/2	156,013	1/2	1/2	1/2	1/2	1/2	1/2	1/2	1/2
3/4	108,977	3/4	119,384	3/4	129,792	3/4	140,199	3/4	150,605	3/4	156,013	3/4	3/4	3/4	3/4	3/4	3/4	3/4	3/4
6	109,193	6	119,601	6	130,008	6	140,416	6	150,822	6	156,013	6	6	6	6	6	6	6	6
1/4	109,410	1/4	119,818	1/4	130,225	1/4	140,633	1/4	151,039	1/4	156,013	1/4	1/4	1/4	1/4	1/4	1/4	1/4	1/4
1/2	109,627	1/2	120,035	1/2	130,442	1/2	140,850	1/2	151,256	1/2	156,013	1/2	1/2	1/2	1/2	1/2	1/2	1/2	1/2
3/4	109,844	3/4	120,251	3/4	130,659	3/4	141,066	3/4	151,472	3/4	156,013	3/4	3/4	3/4	3/4	3/4	3/4	3/4	3/4
7	110,061	7	120,468	7	130,876	7	141,283	7	151,689	7	156,013	7	7	7	7	7	7	7	7
1/4	110,277	1/4	120,685	1/4	131,093	1/4	141,500	1/4	151,906	1/4	156,013	1/4	1/4	1/4	1/4	1/4	1/4	1/4	1/4
1/2	110,494	1/2	120,902	1/2	131,309	1/2	141,717	1/2	152,123	1/2	156,013	1/2	1/2	1/2	1/2	1/2	1/2	1/2	1/2
3/4	110,711	3/4	121,119	3/4	131,526	3/4	141,934	3/4	152,339	3/4	156,013	3/4	3/4	3/4	3/4	3/4	3/4	3/4	3/4
8	110,928	8	121,336	8	131,743	8	142,151	8	152,556	8	156,013	8	8	8	8	8	8	8	8
1/4	111,145	1/4	121,552	1/4	131,960	1/4	142,367	1/4	152,773	1/4	156,013	1/4	1/4	1/4	1/4	1/4	1/4	1/4	1/4
1/2	111,362	1/2	121,769	1/2	132,177	1/2	142,584	1/2	152,990	1/2	156,013	1/2	1/2	1/2	1/2	1/2	1/2	1/2	1/2
3/4	111,578	3/4	121,986	3/4	132,394	3/4	142,801	3/4	153,207	3/4	156,013	3/4	3/4	3/4	3/4	3/4	3/4	3/4	3/4
9	111,795	9	122,203	9	132,610	9	143,018	9	153,423	9	156,013	9	9	9	9	9	9	9	9
1/4	112,012	1/4	122,420	1/4	132,827	1/4	143,235	1/4	153,635	1/4	156,013	1/4	1/4	1/4	1/4	1/4	1/4	1/4	1/4
1/2	112,229	1/2	122,636	1/2	133,044	1/2	143,451	1/2	153,846	1/2	156,013	1/2	1/2	1/2	1/2	1/2	1/2	1/2	1/2
3/4	112,446	3/4	122,853	3/4	133,261	3/4	143,668	3/4	154,057	3/4	156,013	3/4	3/4	3/4	3/4	3/4	3/4	3/4	3/4
10	112,663	10	123,070	10	133,478	10	143,885	10	154,269	10	156,013	10	10	10	10	10	10	10	10
1/4	112,879	1/4	123,287	1/4	133,694	1/4	144,102	1/4	154,442	1/4	156,013	1/4	1/4	1/4	1/4	1/4	1/4	1/4	1/4
1/2	113,096	1/2	123,504	1/2	133,911	1/2	144,318	1/2	154,616	1/2	156,013	1/2	1/2	1/2	1/2	1/2	1/2	1/2	1/2
3/4	113,313	3/4	123,721	3/4	134,128	3/4	144,535	3/4	154,789	3/4	156,013	3/4	3/4	3/4	3/4	3/4	3/4	3/4	3/4
11	113,530	11	123,937	11	134,345	11	144,752	11	154,962	11	156,013	11	11	11	11	11	11	11	11
1/4	113,747	1/4	124,154	1/4	134,562	1/4	144,969	1/4	155,093	1/4	156,013	1/4	1/4	1/4	1/4	1/4	1/4	1/4	1/4
1/2	113,963	1/2	124,371	1/2	134,779	1/2	145,186	1/2	155,223	1/2	156,013	1/2	1/2	1/2	1/2	1/2	1/2	1/2	1/2
3/4	114,180	3/4	124,588	3/4	134,995	3/4	145,402	3/4	155,353	3/4	156,013	3/4	3/4	3/4	3/4	3/4	3/4	3/4	3/4

CERTIFIED CHART FOR THE ABOVE NAMED TANK ONLY.

STRAPPED: 02/08/2007 CL - SW
CALCULATED: 02/08/2007 CL
PRINTED: 02/08/2007 CL

CANCELS AND SUPERCEDES
ALL PRIOR TO 02/2007

PRECISION MEASUREMENT
& ANALYSIS, INC.

P.O. Box 2092
Pearland, Texas 77588
<http://www.pmacorp.net>